



## The 21st Century premium implant system

Volume AR C3.0

# AnyRidge®

## ➔ Contents

### Characteristic and Advantages

I. Surgery	05
II. Prosthetics	06
III. Maintenance	07

### AnyRidge® Dimension & Sizes

Fixture Dimension & Size	08
Fixture Package	12

### Abutment options

- Fixture level prosthetics	16
- Abutment level / Solid abutment prosthetics	24

### All-In-One Package

- Abutment level / Octa abutment prosthetics	29
- Abutment level / Multi-unit prosthetics	30
- Abutment level / Multi-unit prosthetics	34
- Abutment level / Flat abutment prosthetics	39
- Overdenture prosthetics	42

### How to seal a screw hole?

45

### AnyRidge® Surgical Kit & Components

46

### Prosthetic systems

Prosthetics kit	53
Abutment selection guide kit	54

### BonEX Kit

55



# ➔ Design Concept

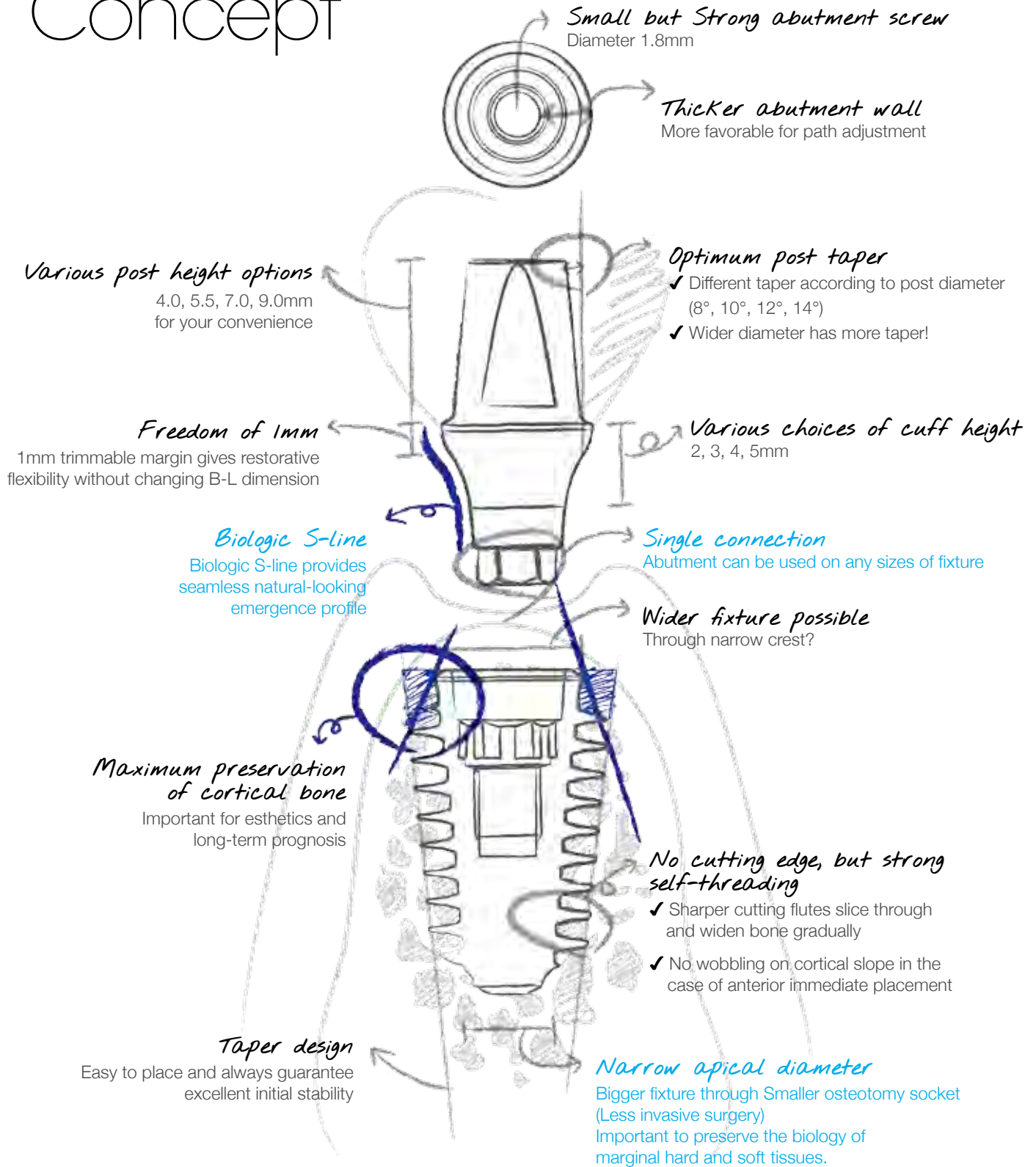

# SLA surface with $Ca^{2+}$ incorporated

MegaGen has developed surface treatment based on SLA technique with nano layer of  $Ca^{2+}$  incorporated. Ion creates a  $CaTiO_3$  nanostructure on the surface, and activates osteoblasts in the live bone. The name of this unique specialized surface treatment is XPEED®.

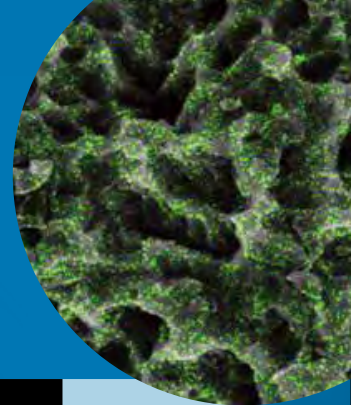

Fast & Strong Osseointegration

## Bigger BIC resulting bigger removal torque after osseointegration

XPEED® demonstrates bigger BIC and requires bigger removal torque than the RBM or conventional SLA surface treatments.

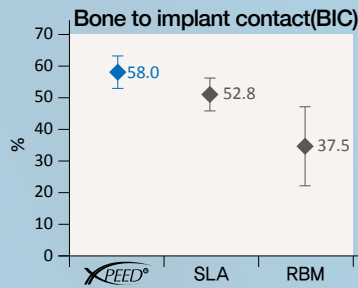

## Histological analysis

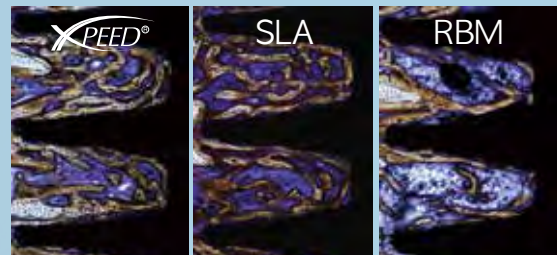

Test result after 4 weeks with rabbit

Histological sections of Ti implants with XPEED® SLA, RBM and surface shows the XPEED® makes the highest BIC and makes new bone full between threads. Bone contact was measured over the entire surface of Ti implants.

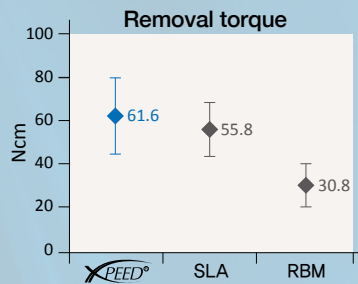

Blue colored surface as the evidence of purity

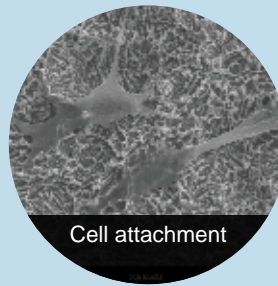

Cell attachment

During the factory process of XPEED® treatment, the SLA surface is completely neutralized to remove any acid residue. The blue color of XPEED® surface is the symbol of purity.



Nano-Thickness

XPEED® is different from conventional HA coating technique. Because  $Ca^{2+}$  ions are incorporated XPEED® will not result peeling or absorption after fixture installation.

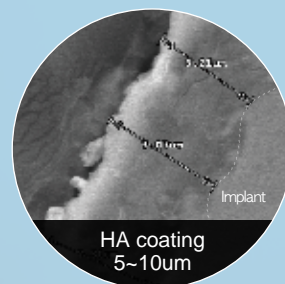
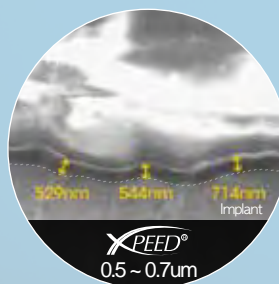

# ➔ I. Surgery

Excellent initial stability, even at compromised bone density. AnyRidge® cuts through bone smoothly and condenses it simultaneously.

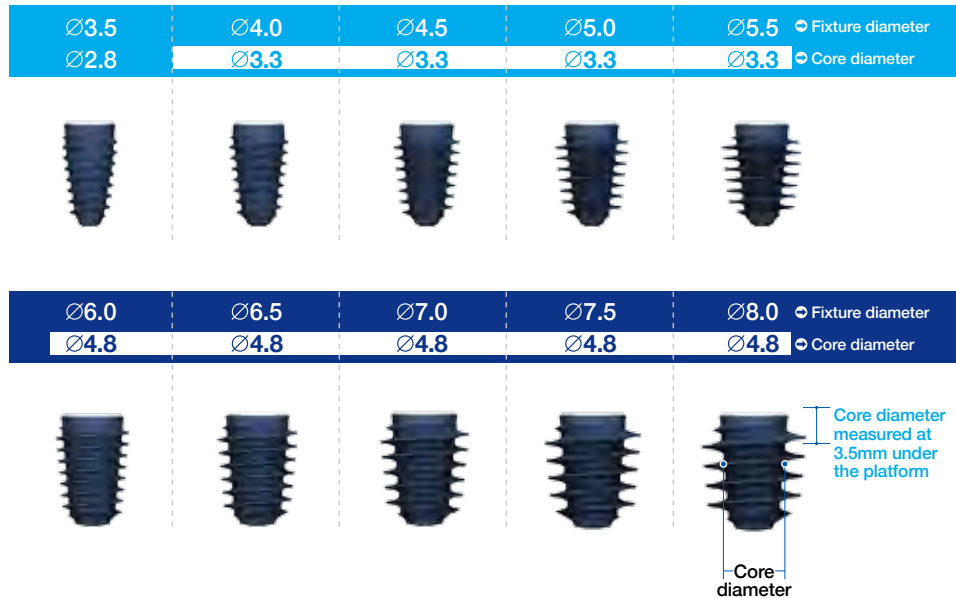

## 1. Fixture placement

### • Soft bone

The super self-tapping threads have a single core diameter that facilitates minimal site preparation by utilizing a smaller osteotomy to place a wider fixture with special threads.

### • Hard bone

AnyRidge® with its super thread design is easier to place than other traditional implants at hard bone. *\*Caution! : The osteotomy socket drilling size should almost reach the size of fixture to avoid getting struck in the bone during placement!*

## 2. Customized drilling Sequence

- AnyRidge® has no fixed protocol for drilling. Make your own drilling protocol according to patient's bone quality to attain your preferred initial stability. Or you can simply drill an osteotomy socket adequate to the given conditions and then decide the diameter of the fixture according to the bone density.

Example 1) A 5mm diameter fixture can be placed in a 2.9mm osteotomy socket at D4 bone. Excellent initial stability will be attained.



Example 2) At hard bone, you are advised to make an osteotomy almost to the size of a fixture.

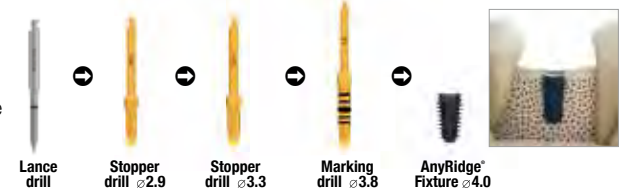

- Improved drill design is the secret of simplified drilling sequence. You can even harvest autogenous bone with these specially designed drills. (Recommended speed : 50 RPM, 50 Ncm without water irrigation)
- The best way to get ideal initial stability with the AnyRidge system is by placing an implant with a implant engine, leaving one or two threads above the crest. Then use a ratchet wrench to place the platform at the desired position.

# ➔ II. Prosthetics

Better esthetic outcomes from wide variety of prosthetic options!  
Stop worrying about screw loosening!

## 1. No screw loosening, Less biologic width!

### • Magic Five (5° Internal connection)

Now you can be free from worrying about screw loosening with our unique connection 5 degree morse taper which gives perfect hermetic sealing. Biologic width is minimized due to no micro gap, and crestal bone health is well maintained.

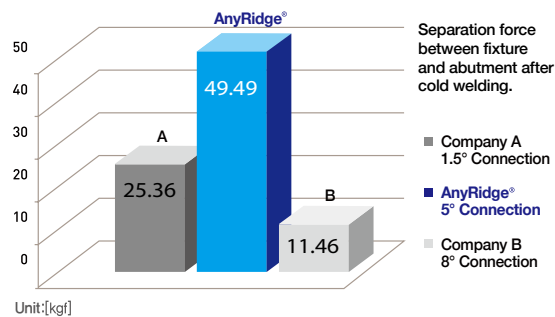

## 2. Biologic s-line

Helps to achieve beautiful, natural-looking esthetics.

## 3. Optimum hex height

Your fingers will feel the difference of the AnyRidge connection. It starts with impression taking and lasts until final restoration.

## 4. All indications, wide Abutment options

Every case, every shape, every size was considered to satisfy the clinician's needs.

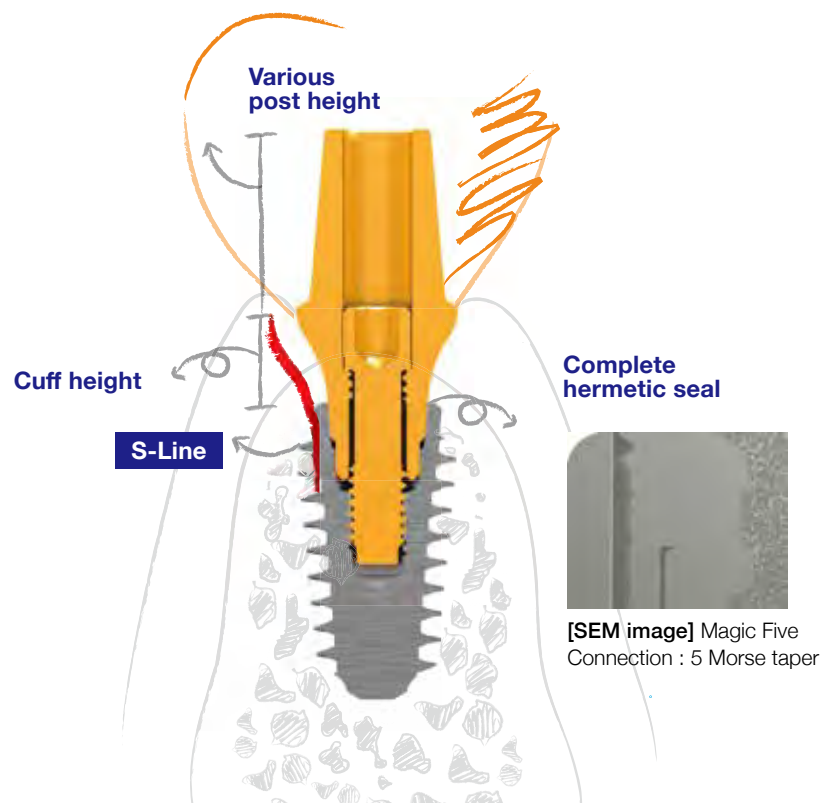

# ➔ III. Maintenance

Unique and sturdy design provides long term stability!

## 1. More cortical bone Preservation is guaranteed

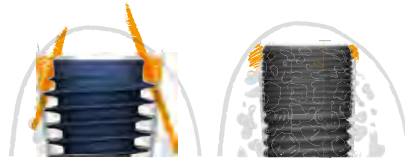

AnyRidge fixtures do not depend on the cortical bone for initial stability! Decreased stress on the cortical bone helps to prevent bone resorption following fixture placement.

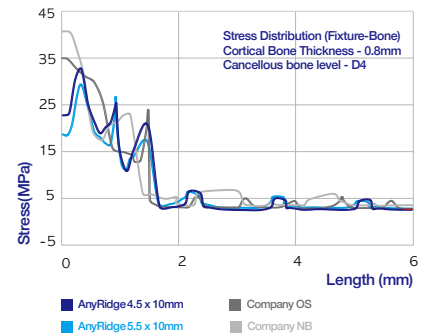

- **More cortical bone = More soft tissue volume = Beautiful gingival line**

Advanced coronal design allows maximum cortical bone preservation around implants. Beyond osseointegration, AnyRidge can assure a beautiful gingival line by preserving and maintaining more cortical bone.

## 2. Innovative thread design

### KnifeThread® - Round faced and narrow thread design

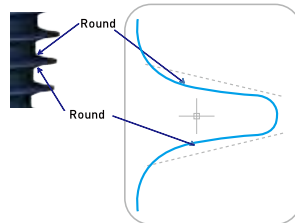

- Less insertion torque
- Excellent initial stabilization ▲
- Resistance to compressive force ▼
- Minimal Shear force creation
- Higher BIC

Thanks to its unique knife thread and super self-tapping design, better initial stability can be attained in any compromised bone situation. It offers progressive bone condensing, ridge expansion, maximized compressive force resistance and minimized shear force production.

## 3. Increased fixture strength

### Compressive strength

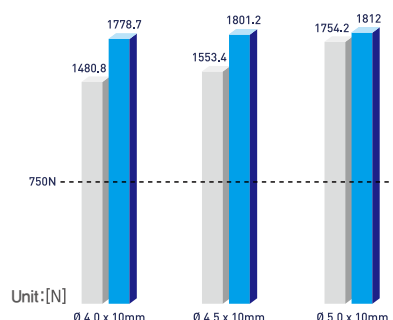

Due to its special thread and core design, AnyRidge fixture indicate better fracture resistance than other 5mm diameter fixtures. A 4.0mm AnyRidge fixture is stronger than a 5.0mm EZ plus fixture.

# ➔ Fixture Dimension

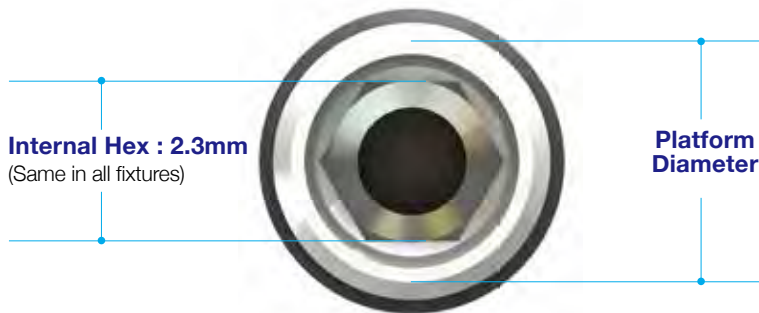

## Relationship between platform diameter and Widest thread diameter

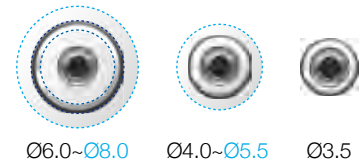

3 Different sizes

- 3.5mm fixture : 3.5mm(platform) / 3.8mm(bevel)
- 4.0~5.5mm fixture : 3.5mm(platform) / 4.0mm(bevel)
- 6.0~8.0mm fixture : 5.0mm(platform) / 5.5mm(bevel)

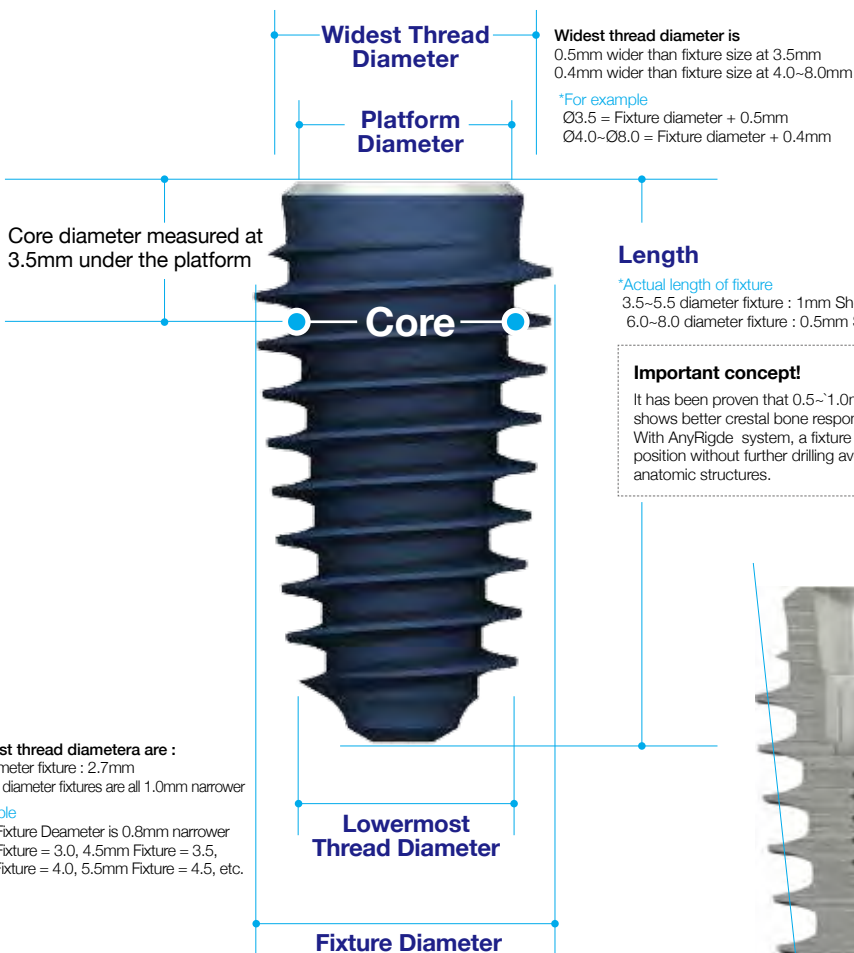

**Lower most thread diameter are :**  
3.5mm diameter fixture : 2.7mm  
4.0~8.0mm diameter fixtures are all 1.0mm narrower

*\*For example*  
- 3.5mm Fixture Diameter is 0.8mm narrower  
- 4.0mm Fixture = 3.0, 4.5mm Fixture = 3.5,  
5.0mm Fixture = 4.0, 5.5mm Fixture = 4.5, etc.

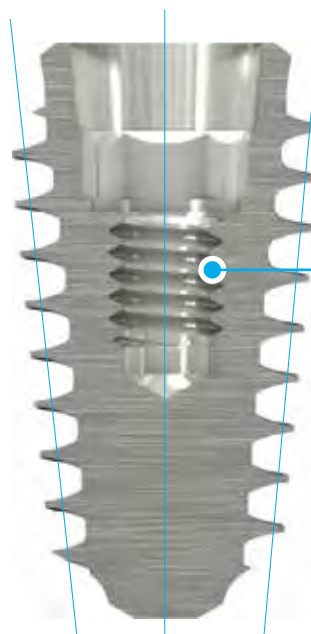



# → Fixture Size

## Small Ø3.5

Ref.C	Fixture diameter (mm)	Length (mm)
FANIH3507C	3.5	7
FANIH3508C		8.5
FANIH3510C		10
FANIH3511C		11.5
FANIH3513C		13
FANIH3515C		15

- Availability of 7mm product is subject to local approval.
- CE certified only. Not for Korean domestic users.

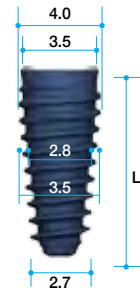

## Regular Ø4.0

Ref.C	Fixture diameter (mm)	Length (mm)
FANIH4007C	4.0	7
FANIH4008C		8.5
FANIH4010C		10
FANIH4011C		11.5
FANIH4013C		13
FANIH4015C		15

- Availability of 7mm product is subject to local approval.
- CE certified only. Not for Korean domestic users.

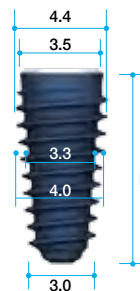

## Regular Ø4.5

Ref.C	Fixture diameter (mm)	Length (mm)
FANIH4507C	4.5	7
FANIH4508C		8.5
FANIH4510C		10
FANIH4511C		11.5
FANIH4513C		13
FANIH4515C		15

- Availability of 7mm product is subject to local approval.

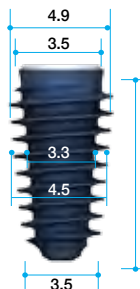

# ➔ Fixture Size

## Wide Ø5.0

Ref.C	Thread diameter (mm)	Length (mm)
FANIH5007C	5.0	7
FANIH5008C		8.5
FANIH5010C		10
FANIH5011C		11.5
FANIH5013C		13
FANIH5015C		15

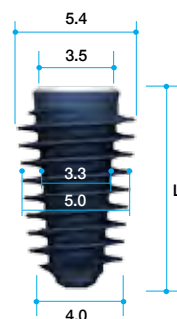

## Wide Ø5.5

Ref.C	Thread diameter (mm)	Length (mm)
FANIH5507C	5.5	7
FANIH5508C		8.5
FANIH5510C		10
FANIH5511C		11.5
FANIH5513C		13
FANIH5515C		15

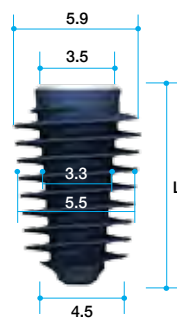

## Super Wide Ø6.0

Ref.C	Thread diameter (mm)	Length (mm)
FALIH6007C	6.0	7
FALIH6008C		8.5
FALIH6010C		10
FALIH6011C		11.5
FALIH6013C		13

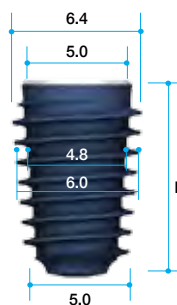

## Super Wide Ø6.5

Ref.C	Thread diameter (mm)	Length (mm)
FALIH6507C	6.5	7
FALIH6508C		8.5
FALIH6510C		10
FALIH6511C		11.5
FALIH6513C		13

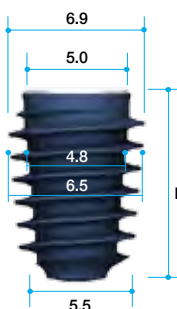

### Super Wide Ø7.0

Ref.C	Thread diameter (mm)	Length (mm)
FALHX7007C	7.0	7
FALHX7008C		8.5
FALHX7010C		10
FALHX7011C		11.5
FALHX7013C		13

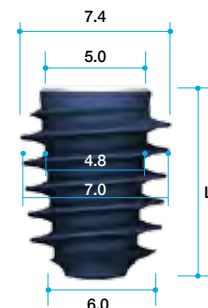

### Super Wide Ø7.5

Ref.C	Thread diameter (mm)	Length (mm)
FALHX7507C	7.5	7
FALHX7508C		8.5
FALHX7510C		10
FALHX7511C		11.5
FALHX7513C		13

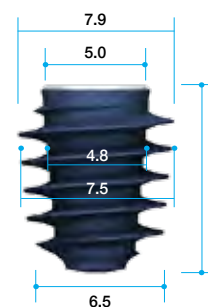

### Super Wide Ø8.0

\* Actual sizes can be differ slightly from catalog references.

Ref.C	Thread diameter (mm)	Length (mm)
FALHX8007C	8.0	7
FALHX8008C		8.5
FALHX8010C		10
FALHX8011C		11.5
FALHX8013C		13

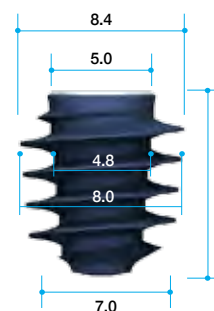

# ➔ Fixture Package



**Upper cover**  
: access to fixture

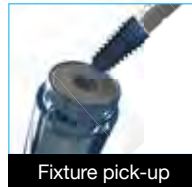
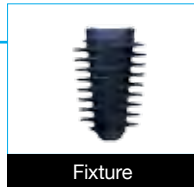

**Lower cover**  
: access to cover screw

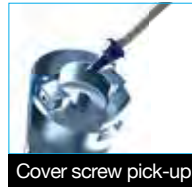
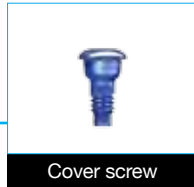

**Ampule** was designed conveniently to be opened with one hand!

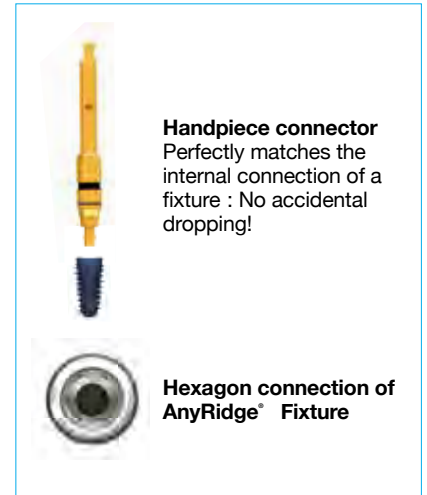

# ➔ Coding

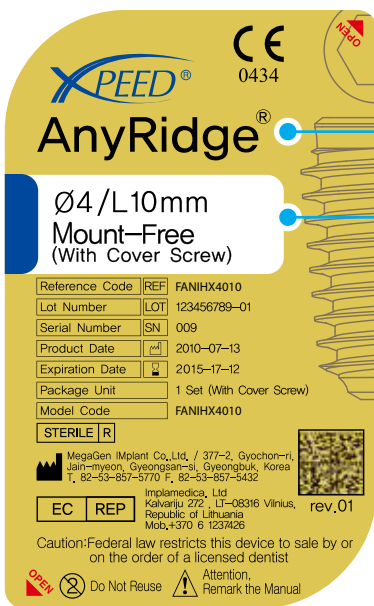

**Different color means different diameter**



# → Cover Screw and Healing Abutment

## Cover Screw

\* included in fixture package

Ref.C	Height (mm)
AANCSF3508	0.8
AANCSF3516	1.6
AANCSF3526	2.6



- Use with a 1.2mm Hand driver.
- Used for submerged type surgery.
- Protects the inner structure of a fixture. fixture replacement.
- Different heights can be chosen according to the position of fixture below the crest.
- 1.6mm and 2.6mm height of cover screw can be purchased separately.

## Healing Abutment

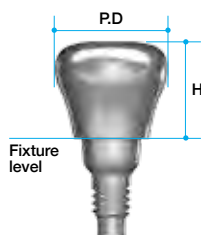

Ref.C	Profile diameter	Height (mm)	
AANHAF0403	Ø4.0	3	
AANHAF0404		4	
AANHAF0405		5	
AANHAF0406		6	
AANHAF0407		7	
AANHAF0503		Ø5.0	3
AANHAF0504			4
AANHAF0505	5		
AANHAF0506	6		
AANHAF0507	7		
AANHAF0603	Ø6.0		3
AANHAF0604			4
AANHAF0605		5	
AANHAF0606		6	
AANHAF0607		7	

Ref.C	Profile diameter	Height (mm)	
AANHAF0703	Ø7.0	3	
AANHAF0704		4	
AANHAF0705		5	
AANHAF0706		6	
AANHAF0707		7	
AANHAF0803		Ø8.0	3
AANHAF0804			4
AANHAF0805	5		
AANHAF0806	6		
AANHAF0807	7		
AANHAF1003	Ø10.0		3
AANHAF1004			4
AANHAF1005		5	
AANHAF1006		6	
AANHAF1007		7	

- Use with a 1.2mm Hand driver.
- Used for non-submerged type surgery or for two stage surgery.
- Choose appropriate diameter and height of healing abutment according to situation.
- Helps to form suitable emergence profile during period of gingival healing.

# ➔ Connection with a Fixture

## 1. All transitional and temporary components have a 'Ledge' on the bottom

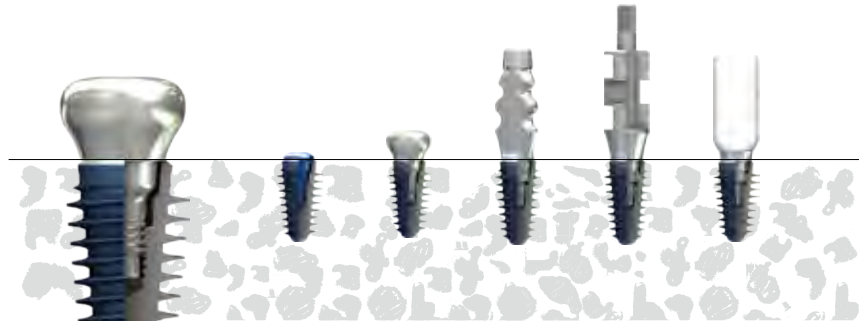

- Cover screws, healing abutments, transfer and pick-up impression copings, titanium and plastic temporary cylinders have ledges on the bottom which prevent from cold welding with a fixture.
- 1.2mm hex drivers or impression coping drivers can be used easily to screw these components in and out.

## 2. All permanent abutments will make a strong connection with a fixture, even with finger force!

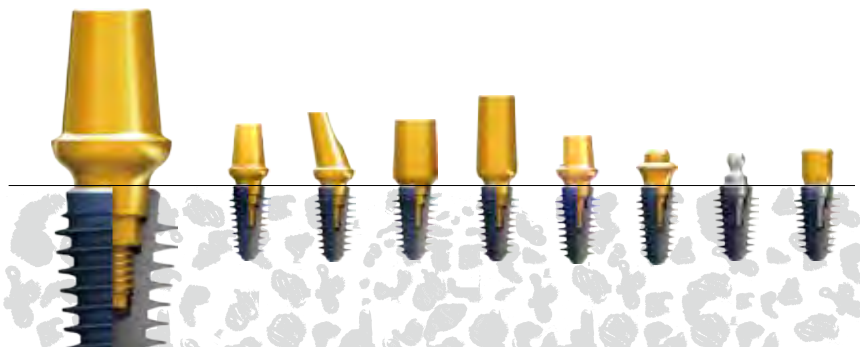

- 25~35Ncm torque force is recommended when permanent abutments are connected into a fixture.
- A fixed abutment cannot be removed with finger force even after complete removal of the abutment screw, because of perfect cold welding. When the removal of a permanent abutment is needed, the specially designed Abutment removal drivers should be used.

# ➔ How to Remove a Permanent Abutment from a Fixture?

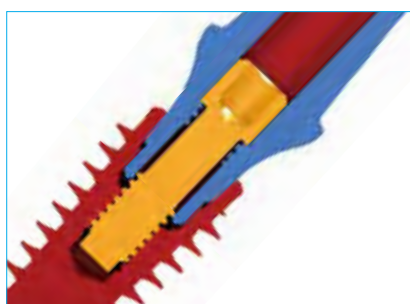

1. Use a 1.2mm hex hand driver to unscrew abutment screw.
2. Continue to turn counter-clockwise until you feel clicks of disengagement.



3. Push down the hand driver once again to catch and fix the abutment screw
4. Lift-up the hand driver with light force and continue to turn counter-clockwise until the abutment screw engages with the inner screws on the abutment



5. Remove the abutment screw completely from the abutment
6. Insert an 'abutment removal driver' and continue to turn clockwise until the abutment comes out of fixture. You can feel some resistance during screw-down of the Abutment removal driver, but don't worry, simple exert more force to disconnect the abutment from the fixture

## Abutment Removal Driver

Ref.C	Length (mm)
TANMRD18	17.5
TANMRD25	25.0

- Use to remove final abutment; use after removing abutment screw.
- Insert straight into the abutment and rotate clockwise.
- Long abutment removal driver is to disconnect an abutment with a cemented crown.



# ➔ Fixture Level Prosthesis

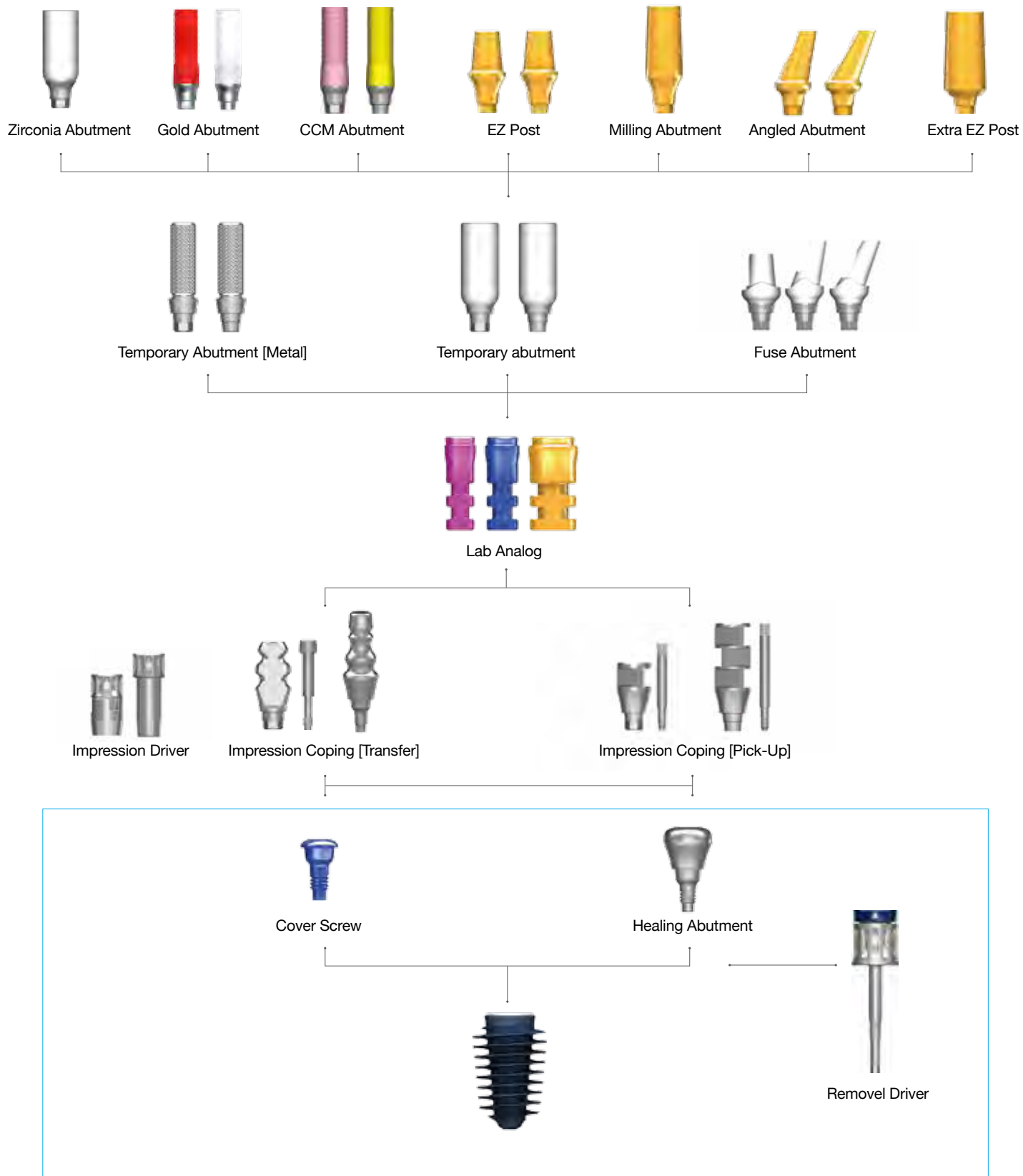



# ➔ Abutment Options

## Impression Coping

(Transfer Type)  
(For Closed-tray Technique)

Type	Ref.C	Profile diameter	Height (mm)
2-Piece	AANITH4012T	Ø4.0	12
	AANITH4016T		16
	AANITH5012T	Ø5.0	12
	AANITH5016T		16
2-Piece (1.2 Hex driver)	AANITH4012HT	Ø4.0	12
	AANITH4016HT		16
	AANITH5012HT	Ø5.0	12
	AANITH5016HT		16

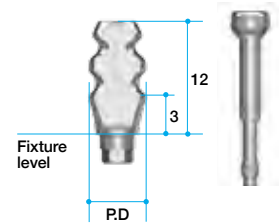

- Used for impression with closed tray.
- Streamlined shape ; easy to transfer.
- Anti-rotation grooves match with hex structure of fixtures.
- Should be tightened with impression coping driver+1.2 Hex driver

## Impression Coping

(Transfer Type)

Type	Ref.C	Profile diameter	Height (mm)
1-Piece	AANITN4012	Ø4.0	12
	AANITN4016		16
	AANITN5012	Ø5.0	12
	AANITN5016		16
1-Piece (1.2 Hex driver)	AANITN4012H	Ø4.0	12
	AANITN4016H		16
	AANITN5012H	Ø5.0	12
	AANITN5016H		16

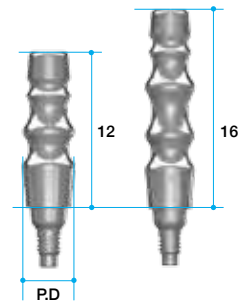

## Impression Driver

Ref.C	Length (mm)
TCMID	Short
TCMIDE	Long



- For transfer type impression coping.
- Works with friction only.
- Small but powerful grip.

## Impression Coping

(Pick-up Type)  
(For Open-tray Technique)

- Guide pins : AANGPP0010 (7mm : Short) /  
AANGPP0015 (12mm : Long) / AANGPP0020  
(20mm : Extra-long)

Type	Ref.C	Profile diameter	Height (mm)
2-Piece	AANIPH4012T	Ø4.0	12
	AANIPH4016T		16
	AANIPN4012T		12
	AANIPN4016T		16
	AANIPH5007T	Ø5.0	7
	AANIPH5012T		12
	AANIPN5007T		7
	AANIPN5012T		12

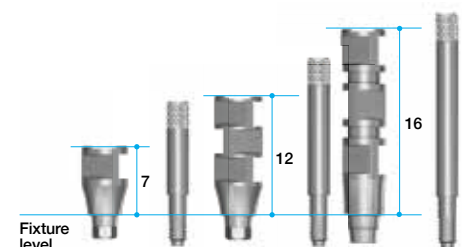

- Used for impression with open tray.
- Square structure - strong anti - rotation function.
- Designed for easy and accurate pick-up impression.
- Extra-long guide pin can be purchased separately.

# ➔ Abutment Options

## Lab Analog (Fixture Level)

Ref.C	Type	Color
AANLAF4055	Basic	Blue

- All sizes of fixtures have a uniform connection.
- Only one fixture analog is sufficient.  
(Exceptional case)



## Temporary Abutment (Titanium)

- Multi post screw(AANMSF) included

Type	Ref.C	Profile diameter	Cuff Height (mm)
Hex	AANTMH4012T	Ø4.0	2
Non-Hex	AANTMN4012T		

- For making provisional restoration.
- Grooved on the post allows strong resin adherence.

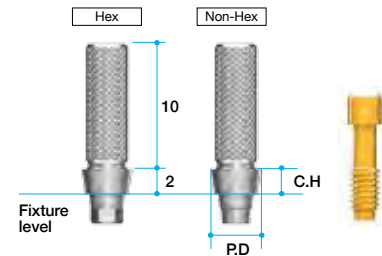

## Temporary Abutment (Plastic with Metal Base)

- Multi post screw(AANMSF) included

Type	Ref.C	Profile diameter	Cuff Height (mm)
Hex	AANTAH5012T	Ø5.0	1
Non-Hex	AANTAN5012T		

- For making esthetic provisional restorations, especially after immediate implant placement in esthetic zone.
- Easy to customize with a high speed handpiece and diamond burs.

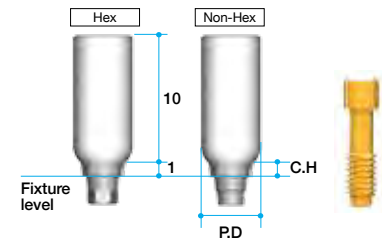

## Fuse Abutment

- Abutment screw + Fuse cap included

Type	Diameter		Cuff (mm)	Height (mm)	Ref.C
	Labio-lingual	Mesio-distal			
Straight		Ø5.5	3	5.5	AFAP5535P
15°	Ø5.5	Ø4.5		7	AFAA5315P
25°				AFAA5325P	

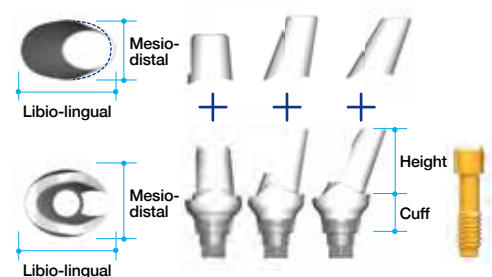

# ➔ Fuse Abutment™

## Design concept of Fuse Abutment™

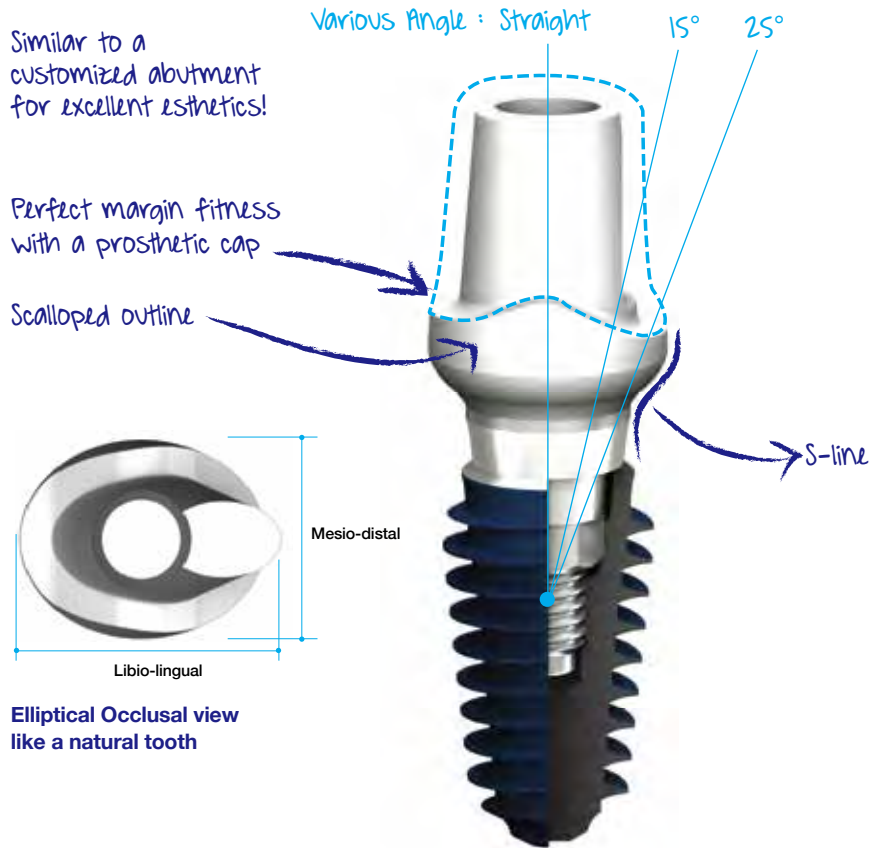

**Elliptical Occlusal view like a natural tooth**

## Rationale of Fuse Abutment™

In 1992, Brunski JB. reported that an implant may have higher possibility of fibrous-integration than osseo-integration between bone and implant surface when movements more than 100µm occurs on the fixture during osseointegration period. (John B. Brunski, Biomechanical factors affecting the bone-dental implant interface. Clinical Materials, Vol. 10, 153-201) Therefore, the implant is needed to be protected not to move when immediate loading is carried out. However, it is not easy to manage loading on the fixture, even when we use a resin temporary with a titanium cylinder. It was thought that it's partly because of the metal component of temporary cylinder, which can deliver excessive forces to the fixture. This is one of the reasons which make clinicians hesitate the immediate loading procedure. So it is necessary to develop a special temporary cylinder. It should be broken under the force which can lead fibrointegration or failure of osseointegration to protect the fixture. and it will be preferred if it is easy to make a temporary crown on this particular temporary cylinder. We tried to measure the force causing movement of 100µm on a fixture which was placed securely into adequate

density of bone without defect. First, AnyRidge implants were placed into the internationally recognized standard bone block with more 40Ncm torque force and an abutment was connected on each implant. Instron was used to measure the force to move a fixture 100µm. The average force was 220N (22.4 kgf). Therefore, If the new temporary abutment can be fractured under this force, it may protect the fixture from movement or failure.

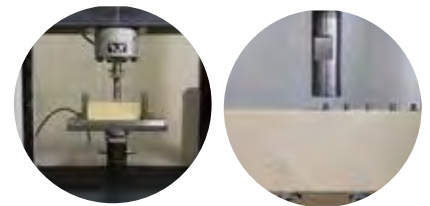

From this experiment, we could developed a special temporary abutment which has lower fracture threshold of less than 200 N (20.4 kgf). It was named as Fuse Abutment. Also it has an anatomic profiles to make temporary prosthetics more esthetic.

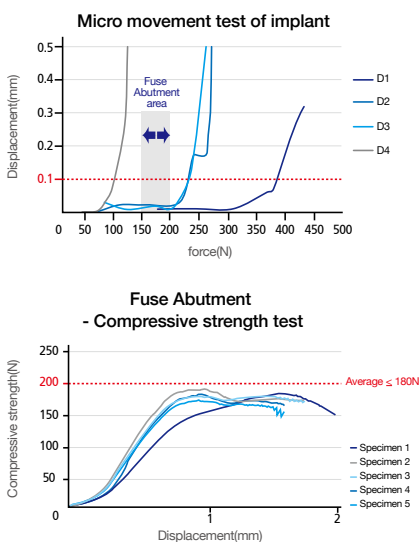

# ➔ Abutment Options

## EZ Post (Fixture Level)

- Multi post screw(AANMSF/AANMST) included.

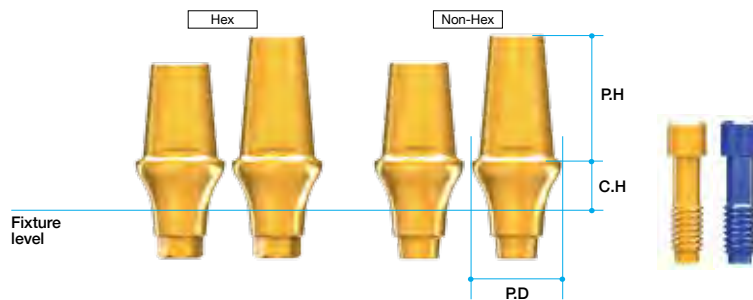

Type	Ref.C	Profile diameter	Cuff Height(mm)	Post Height(mm)
Hex	AANEPH4025L	Ø4.5	2	5.5
	AANEPH4035L		3	
	AANEPH4045L		4	
	AANEPH4055L		5	
	AANEPH4027L		2	7
	AANEPH4037L		3	
	AANEPH4047L		4	
	AANEPH4057L		5	
Non-Hex	AANEPN4025L	Ø4.5	2	5.5
	AANEPN4035L		3	
	AANEPN4045L		4	
	AANEPN4055L		5	
	AANEPN4027L		2	7
	AANEPN4037L		3	
	AANEPN4047L		4	
	AANEPN4057L		5	
Hex	AANEPH5025L	Ø5.0	2	5.5
	AANEPH5035L		3	
	AANEPH5045L		4	
	AANEPH5055L		5	
	AANEPH5027L		2	7
	AANEPH5037L		3	
	AANEPH5047L		4	
	AANEPH5057L		5	
Non-Hex	AANEPN5025L	Ø5.0	2	5.5
	AANEPN5035L		3	
	AANEPN5045L		4	
	AANEPN5055L		5	
	AANEPN5027L		2	7
	AANEPN5037L		3	
	AANEPN5047L		4	
	AANEPN5057L		5	

- Use with a 1.2mm Hand driver.
- Esthetic gold coloring.
- Two different post heights. (5.5 & 7.0)

Type	Ref.C	Profile diameter	Cuff Height(mm)	Post Height(mm)
Hex	AANEPH6025L	Ø6.0	2	5.5
	AANEPH6035L		3	
	AANEPH6045L		4	
	AANEPH6055L		5	
	AANEPH6027L		2	7
	AANEPH6037L		3	
	AANEPH6047L		4	
	AANEPH6057L		5	
Non-Hex	AANEPN6025L	Ø6.0	2	5.5
	AANEPN6035L		3	
	AANEPN6045L		4	
	AANEPN6055L		5	
	AANEPN6027L		2	7
	AANEPN6037L		3	
	AANEPN6047L		4	
	AANEPN6057L		5	
Hex	AANEPH7025L	Ø7.0	2	5.5
	AANEPH7035L		3	
	AANEPH7045L		4	
	AANEPH7055L		5	
	AANEPH7027L		2	7
	AANEPH7037L		3	
	AANEPH7047L		4	
	AANEPH7057L		5	
Non-Hex	AANEPN7025L	Ø7.0	2	5.5
	AANEPN7035L		3	
	AANEPN7045L		4	
	AANEPN7055L		5	
	AANEPN7027L		2	7
	AANEPN7037L		3	
	AANEPN7047L		4	
	AANEPN7057L		5	

- Four different profile diameters. (4.0, 5.0, 6.0 & 7.0)
- Four different cuff heights. (2.0, 3.0, 4.0 & 5.0)
- Abutment screw included.

## UCLA Abutment (Gold)

- Multi post screw(AANMSF/AANMST) included.

Type	Ref.C	Profile diameter	Cuff Height(mm)	Post Height(mm)
Hex	AANGAH4012L	Ø4.0	1	11
Non-Hex	AANGAN4012L			

- Useful to make a customized abutment in difficult situations.
- Precious and non-precious alloys.
- Melting point of gold alloy : 1400 - 1450 (Celsius)
- Threaded sleeves for convenient Resin / Wax-up.

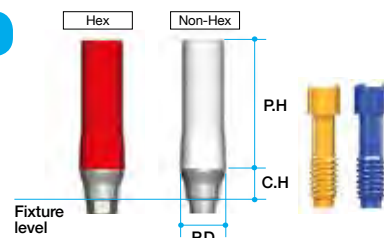

## Zirconia Abutment

- Multi post screw(AANMSF/AANMST) included.

Type	Ref.C	Profile diameter	Cuff Height(mm)	Post Height(mm)
Hex	AANZAH4012L	Ø4.0	1	11
	AANZAH5012L	Ø5.0		

- For aesthetic use.
- Natural white color with pre-sintered zirconia sleeve.

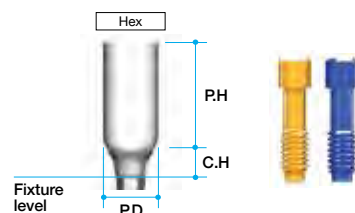

## Milling Abutment

- Multi post screw(AANMSF/AANMST) included.

Ref.C	Profile diameter	Cuff Height(mm)	Post Height(mm)
AANMAH4029L	Ø4.0	2	9
AANMAH4039L		3	
AANMAH4049L		4	
AANMAH4059L		5	
AANMAH5029L	Ø5.0	2	9
AANMAH5039L		3	
AANMAH5049L		4	
AANMAH5059L		5	
AANMAH6029L	Ø6.0	2	9
AANMAH6039L		3	
AANMAH6049L		4	
AANMAH6059L		5	
AANMAH7029L	Ø7.0	2	9
AANMAH7039L		3	
AANMAH7049L		4	
AANMAH7059L		5	

- Long post with 4 different cuff heights and profile diameters enables easier customization by milling.

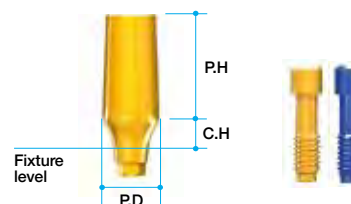

# ➔ Abutment Options

## Angled Abutment

- Multi post screw(AANMSF/AANMST) included

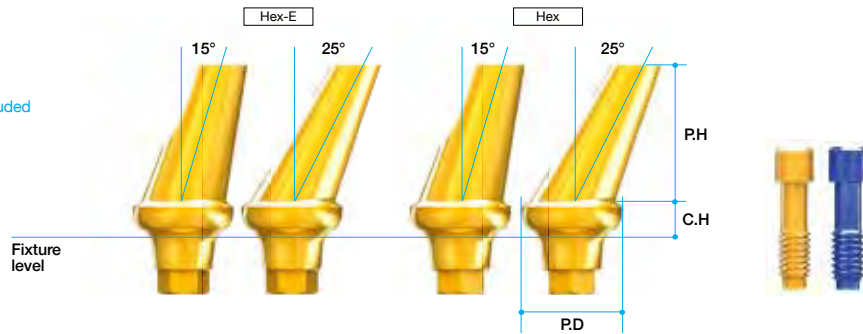

Type	Angle	Ref.C	Profile diameter	Cuff Height(mm)	Post Height(mm)
Hex	15	AANA AH4215L	Ø4.0	2	7
		AANA AH4315L		3	
		AANA AH4415L		4	
		AANA AH4515L		5	
Hex-E	15	AANA AE4215L		2	
		AANA AE4315L		3	
		AANA AE4415L		4	
		AANA AE4515L		5	
Hex	25	AANA AH4225L		2	
		AANA AH4325L		3	
		AANA AH4425L		4	
		AANA AH4525L		5	
Hex-E	25	AANA AE4225L	2		
		AANA AE4325L	3		
		AANA AE4425L	4		
		AANA AE4525L	5		
Hex	15	AANA AH5215L	Ø5.0	2	7
		AANA AH5315L		3	
		AANA AH5415L		4	
		AANA AH5515L		5	
Hex-E	15	AANA AE5215L		2	
		AANA AE5315L		3	
		AANA AE5415L		4	
		AANA AE5515L		5	
Hex	25	AANA AH5225L		2	
		AANA AH5325L		3	
		AANA AH5425L		4	
		AANA AH5525L		5	
Hex-E	25	AANA AE5225L	2		
		AANA AE5325L	3		
		AANA AE5425L	4		
		AANA AE5525L	5		
Hex	15	AANA AH6215L	Ø6.0	2	7
		AANA AH6315L		3	
		AANA AH6415L		4	
		AANA AH6515L		5	
Hex-E	15	AANA AE6215L		2	
		AANA AE6315L		3	
		AANA AE6415L		4	
		AANA AE6515L		5	
Hex	25	AANA AH6225L		2	
		AANA AH6325L		3	
		AANA AH6425L		4	
		AANA AH6525L		5	
Hex-E	25	AANA AE6225L	2		
		AANA AE6325L	3		
		AANA AE6425L	4		
		AANA AE6525L	5		
Hex	15	AANA AH7215L	Ø7.0	2	7
		AANA AH7315L		3	
		AANA AH7415L		4	
		AANA AH7515L		5	
Hex-E	15	AANA AE7215L		2	
		AANA AE7315L		3	
		AANA AE7415L		4	
		AANA AE7515L		5	
Hex	25	AANA AH7225L		2	
		AANA AH7325L		3	
		AANA AH7425L		4	
		AANA AH7525L		5	
Hex-E	25	AANA AE7225L	2		
		AANA AE7325L	3		
		AANA AE7425L	4		
		AANA AE7525L	5		

- Two different angulations. (15 / 25)
- Four different profile diameters. (4.0 / 5.0 / 6.0 / 7.0)
- Four different cuff heights. (2 / 3 / 4 / 5)
- Can cover 12 different directions.[six to the surface(Hex), six to the edge of hex(Hex-E)]

- Esthetic gold coloring.
- Abutment screw included.
- Minimized screw head length needs minimum height to prevent milling problems.

## CCM Abutment

- Multi post screw(AANMSF/AANMST) included

Type	Ref.C	Profile diameter	Cuff Height(mm)	Post Height(mm)
Hex	AANCAH4012L	Ø4.0	1	11
Non-Hex	AANCAN4012L			

- Useful to make a customized abutment in difficult situations.
- Can be casted with non-precious alloys(Ni-Cr, Cr-Co alloys).
- Non-precious melting temperature : Depend on Manufacturer
- Threaded sleeves for convenient Resin / Wax-up.
- CCM abutment melting temperature : 1400 - 1450(Celsius)

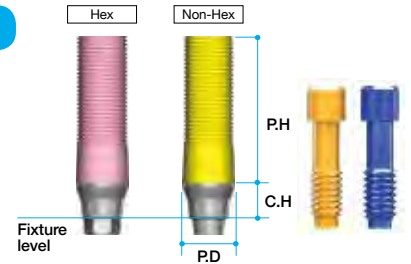

## Extra EZ Post

- Multi post screw(AANMSF/AANMST) included

Ref.C	Profile diameter	Cuff Height(mm)	Post Height(mm)
AANEEH4517L	Ø4.5	1	7
AANEEH5517L	Ø5.5		
AANEEH6517L	Ø6.5		

- Only when satisfactory emergence profile cannot be obtained due to thin gingiva or shallow positioned fixture.
- Useful when fixture is exposed over the gum line.

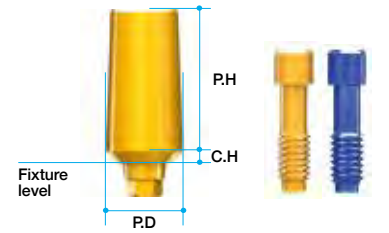

## Lab Analog for use Extra EZ Post

Ref.C	Type	Color
AANLAF35	Extra EZ Post	Magenta
AANLAF4055	Basic	Blue
AANLAF6080	Extra EZ Post	Yellow

- AANEEH4517 used AANLAF35 (Magenta lab analog),
- AANEEH5517 used AANLAF4055 (Blue lab analog),
- AANEEH6517 used AANLAF6080 (Yellow lab analog)



# ➔ Abutment Level / Solid Abutment Prosthesis

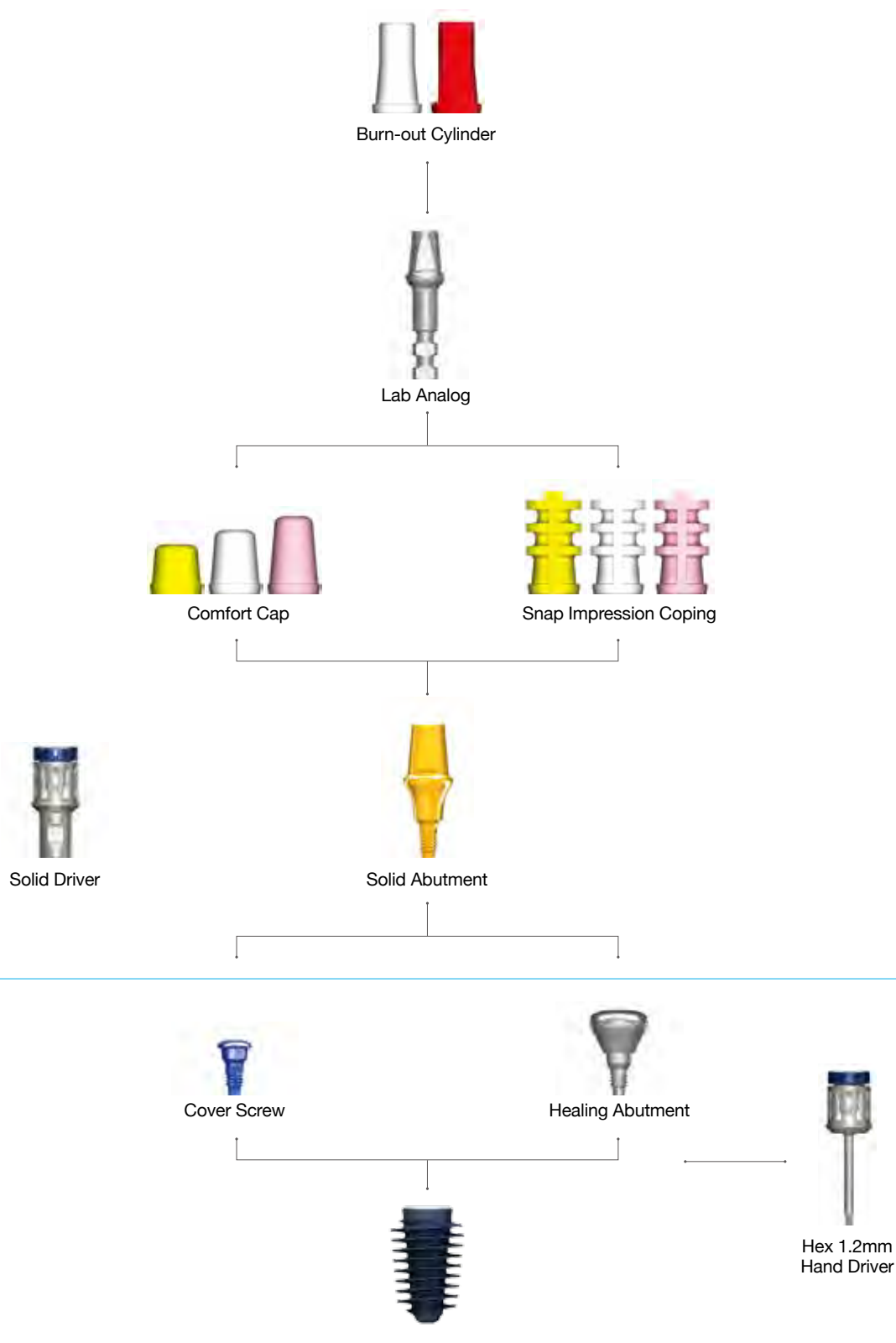



# ➔ Abutment Options

## Solid Abutment

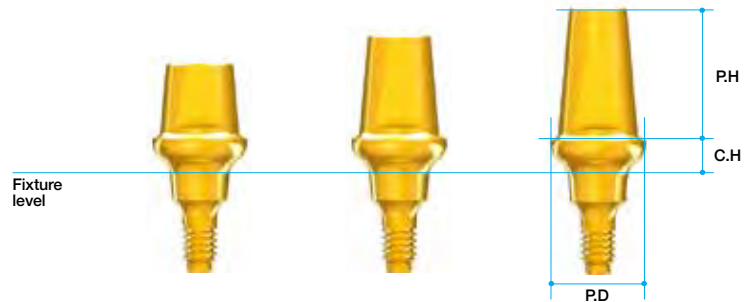

Ref.C	Profile diameter	Cuff Height(mm)	Post Height(mm)	
AANSAL4024	Ø4.0	2	4	
AANSAL4034		3		
AANSAL4044		4		
AANSAL4054		5	5.5	
AANSAL4025		2		
AANSAL4035		3		
AANSAL4045		4		
AANSAL4055		5	7	
AANSAL4027		2		
AANSAL4037		3		
AANSAL4047		4		
AANSAL4057		5		
AANSAL5024		Ø5.0	2	4
AANSAL5034			3	
AANSAL5044			4	
AANSAL5054			5	5.5
AANSAL5025	2			
AANSAL5035	3			
AANSAL5045	4			
AANSAL5055	5		7	
AANSAL5027	2			
AANSAL5037	3			
AANSAL5047	4			
AANSAL5057	5			

Ref.C	Profile diameter	Cuff Height(mm)	Post Height(mm)	
AANSAL6024	Ø6.0	2	4	
AANSAL6034		3		
AANSAL6044		4		
AANSAL6054		5	5.5	
AANSAL6025		2		
AANSAL6035		3		
AANSAL6045		4		
AANSAL6055		5	7	
AANSAL6027		2		
AANSAL6037		3		
AANSAL6047		4		
AANSAL6057		5		
AANSAL7024		Ø7.0	2	4
AANSAL7034			3	
AANSAL7044			4	
AANSAL7054			5	5.5
AANSAL7025	2			
AANSAL7035	3			
AANSAL7045	4			
AANSAL7055	5		7	
AANSAL7027	2			
AANSAL7037	3			
AANSAL7047	4			
AANSAL7057	5			

- Used in cement type prosthetics only.
- Solid abutment should be placed into patient's mouth before taking impression.
- One body (screw + abutment)
- Should be tightened with a solid driver and a torque wrench : 35Ncm

- Four different profile diameters. (4.0/5.0/6.0/7.0)
  - Should be tightened with special solid driver.
  - Wider profile has bigger post angulation. (4mm - 8dgree taper, 5mm - 10dgree, 6mm - 12dgree, 7mm - 14dgree)
- Four different cuff heights. (2/3/4/5)
- Three different post heights. (4/5.5/7)

# ➔ Abutment Options

## Solid Driver

Ref.C	Solid abutment Profile diameter	Length (mm)
TANSDS400	Ø4	8.5
TANSDL400		13.5
TANSDS500	Ø5	8.5
TANSDL500		13.5
TANSDS600	Ø6	8.5
TANSDL600		13.5
TANSDS700	Ø7	8.5
TANSDL700		13.5



- For the delivery of solid abutments.
- Color coded for different profile diameters. (4mm-magenta, 5mm-blue, 6mm-yellow, 7mm-green)
- Two different heights. (8.5 / 13.5)
- Directly connectable to Torque wrench.

## Snap Impression Coping

Ref.C	Profile diameter
AANSIF440	Ø4
AANSIF455	
AANSIF470	
AANSIF540	Ø5
AANSIF555	
AANSIF570	
AANSIF640	Ø6
AANSIF655	
AANSIF670	
AANSIF740	Ø7
AANSIF755	
AANSIF770	

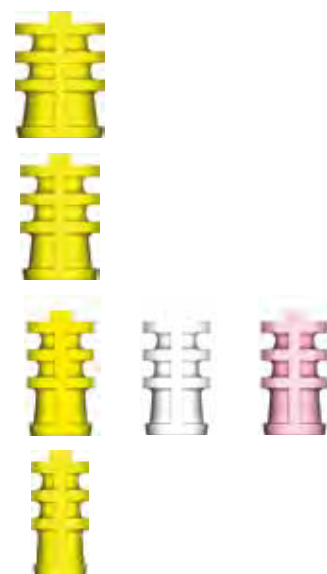

- For impression on solid abutments.
- 3 Color coded for different post heights. [4mm(yellow), 5.5mm(White), 7.0mm(Pink)]
- 4 different diameters for profile diameters. (4 / 5 / 6 / 7)
- Do not use when abutment is trimmed.

## Comfort Cap

Ref.C	Profile diameter	Height (mm)
AANCCF440	Ø4.0	4
AANCCF455		5.5
AANCCF470		7
AANCCF540	Ø5.0	4
AANCCF555		5.5
AANCCF570		7
AANCCF640	Ø6.0	4
AANCCF655		5.5
AANCCF670		7
AANCCF740	Ø7.0	4
AANCCF755		5.5
AANCCF770		7



- Protects the solid abutment and minimizes irritation to tongue and oral mucosa.
- Can be applied under temporary prosthetics.
- Color coded according to post heights.  
[4mm(Yellow), 5.5mm(White), 7mm(Pink)]

## Lab Analog (Solid Level)

Ref.C	Profile diameter	Height (mm)
AANSLF440	Ø4.0	4
AANSLF455		5.5
AANSLF470		7
AANSLF540	Ø5.0	4
AANSLF555		5.5
AANSLF570		7
AANSLF640	Ø6.0	4
AANSLF655		5.5
AANSLF670		7
AANSLF740	Ø7.0	4
AANSLF755		5.5
AANSLF770		7

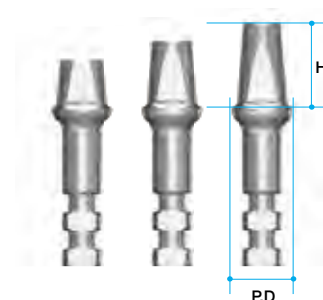

- Directly connected to the snap impression coping in the impression to make a stone model.

# ➔ Abutment Options

## Burn out Cylinder

Type	Ref.C	Profile diameter
Multiple	AANBCB470	Ø4.0
	AANBCB570	Ø5.0
	AANBCB670	Ø6.0
	AANBCB770	Ø7.0
Single	AANBCS470	Ø4.0
	AANBCS570	Ø5.0
	AANBCS670	Ø6.0
	AANBCS770	Ø7.0



- Fits with a solid lab analog.
- Easy to wax-up and accurate casting.
- White cylinder for multiple unit without slot  
Red cylinder for single crown.

## Reamer Drill & Center Pin

Type	Ref.C	Diameter
Handle + Bite	TANRD	Ø10.0
	TANRDJ40	Ø4.0
	TANRDJ50	Ø5.0
	TANRDJ60	Ø6.0
	TANRDJ70	Ø7.0



- Removes inner lip of the cast after casting burn-out cylinders of solid abutment.
- Hand-driver
- 4 different diameters according to the profile diameter of solid abutments.

# ➔ All-In-One Package

Choose an appropriate abutment, and then the rest will follow without headaches.

## 1. All-In-One package composition

Solid abutment + Snap impression coping + Comfort cap + Lab analog + Burn-out cylinder(Single/Bridge)

## 2. All-In-One package order

Solid abutment Reference Code + **'A'**

Ex) Solid abutment AANSAL5025 = Profile Diameter = 5.0 / Cuff Height =2.0 / Post height = 5.5 All In one Package Order

AANSAL5025A = AANSAL5025 + AANSIF555 + AANCCF555 + AANSLF555 + AANBCS570 + AANBCB570

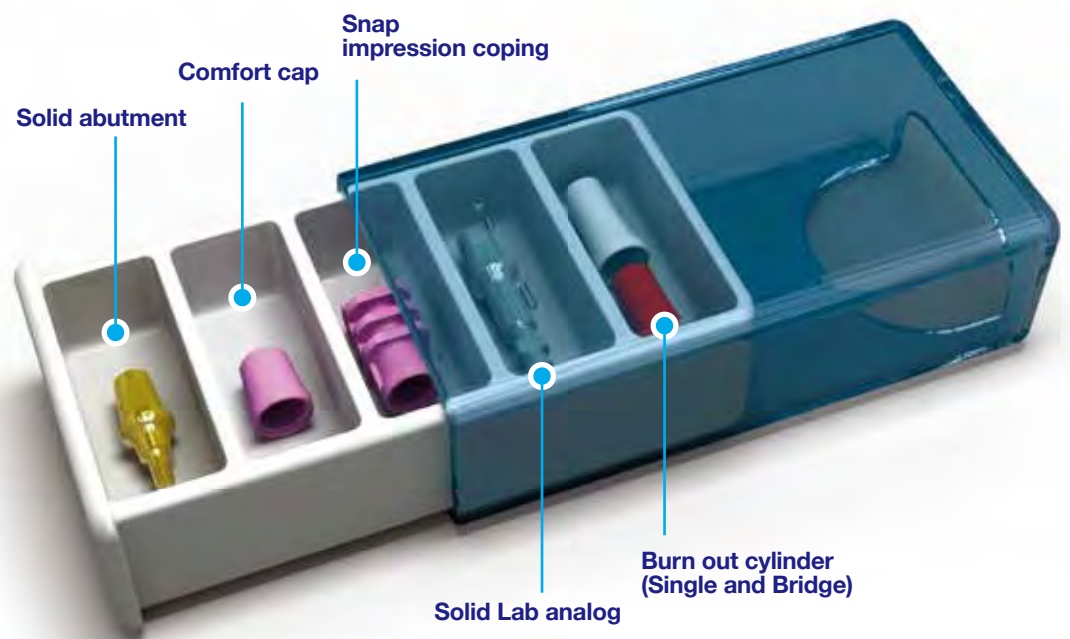

# ➔ Abutment Level / Octa Abutment Prosthesis

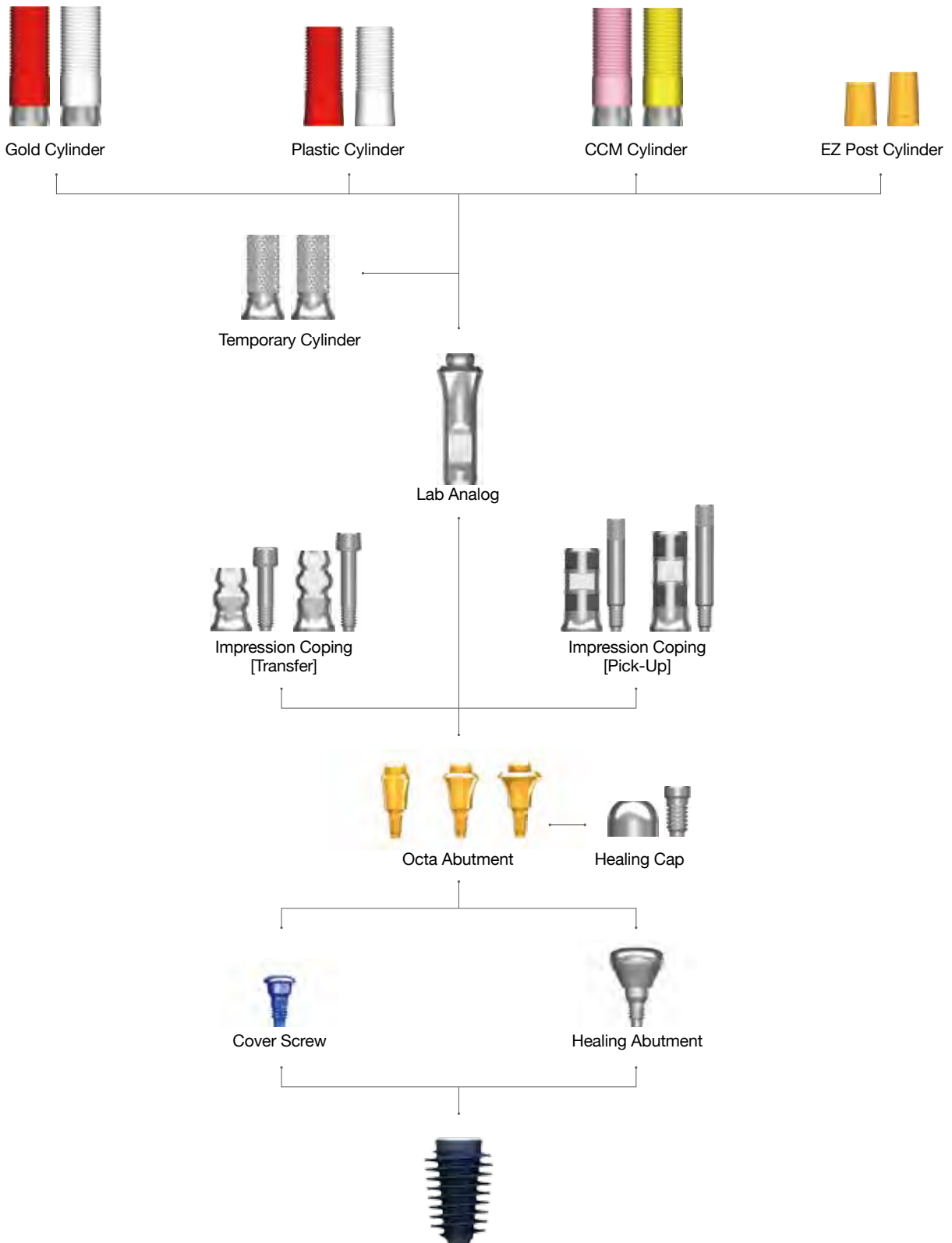

# ➔ Abutment Options

## Octa Abutment

Ref.C	Profile diameter	Cuff Height (mm)
AANOAF4010	Ø4.0	1
AANOAF4020		2
AANOAF4030		3
AANOAF4040		4
AANOAF4050		5
AANOAF0010	Ø5.0	1
AANOAF0020		2
AANOAF0030		3
AANOAF0040		4
AANOAF0050		5
AANOAF6010	Ø6.0	1
AANOAF6020		2
AANOAF6030		3
AANOAF6040		4
AANOAF6050		5

- Used in manufacturing multiple screw-retained prosthetics.
- Compatible with Strauman's octa abutment system.
- Use an octa driver : 35Ncm
- Maximum path angle : 70°

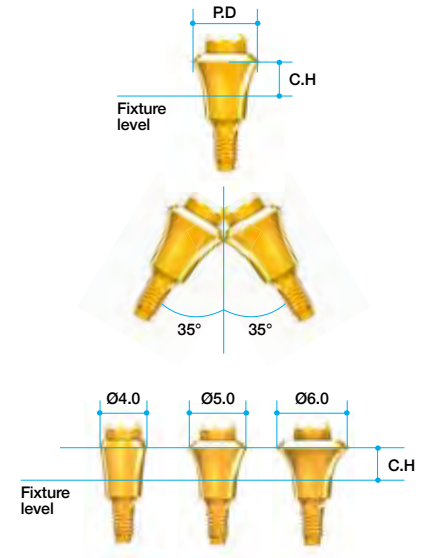

## Healing Cap & Octa Cylinder Cap

- Cylinder screw(IRCS200) included

Ref.C	Profile diameter
AANOHC4000T	Ø4.0
IHC400T	Ø5.0
AANOHC6000T	Ø6.0

- Protects Octa Abutment and minimizes irritation to tongue and oral mucosa.



## Octa Abutment Driver

Ref.C	Length (mm)
MOD300S	7
MOD300L	13

- For seating the Octa Abutment onto the fixture, can also be connected to Torque Wrench.

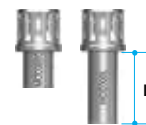

## Octa Impression Coping (Transfer)

- Guide pin included

Type	Ref.C	Profile Height(mm)	Height (mm)
Octa	AAOITO4010T	Ø4.0	7.5
Non-Octa	AAOITN4010T		
Octa	AAOITO4012T	Ø4.0	9.5
Non-Octa	AAOITN4012T		
Octa	AAOITO5010T	Ø5.0	7.5
Non-Octa	AAOITN5010T		
Octa	AAOITO5012T	Ø5.0	9.5
Non-Octa	AAOITN5012T		
Octa	AAOITO6010T	Ø6.0	7.5
Non-Octa	AAOITN6010T		
Octa	AAOITO6012T	Ø6.0	9.5
Non-Octa	AAOITN6012T		

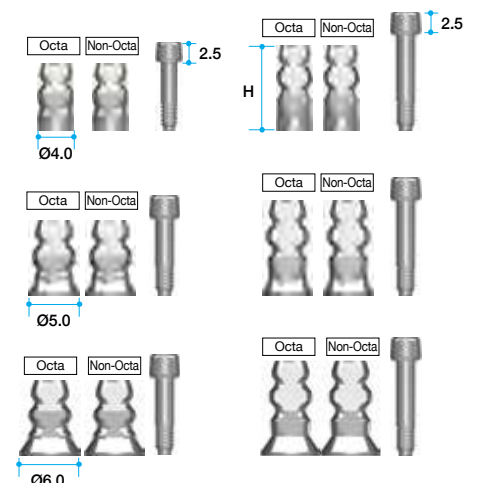

# ➔ Octa Abutment Prosthesis

## Impression Coping

(Pick-Up)

- Guide pin included.

Type	Ref.C	Profile Height(mm)	Height (mm)
Octa	AAOIPO4010T	Ø4.0	10.0
Non-Octa	AAOIPN4010T		10.0
Octa	AAOIPO4012T	Ø4.0	12.0
Non-Octa	AAOIPN4012T		12.0
Octa	AAOIPO5010T	Ø5.0	10.0
Non-Octa	AAOIPN5010T		10.0
Octa	AAOIPO5012T	Ø5.0	12.0
Non-Octa	AAOIPN5012T		12.0
Octa	AAOIPO6010T	Ø6.0	10.0
Non-Octa	AAOIPN6010T		10.0
Octa	AAOIPO6012T	Ø6.0	12.0
Non-Octa	AAOIPN6012T		12.0

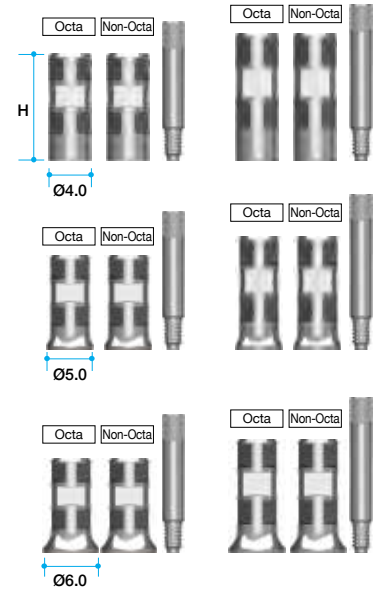

## Lab Analog

Ref.C	Profile diameter(mm)
AANOLA4000	Ø3.8
IOA300	Ø4.8
AANOLA6000	Ø5.8

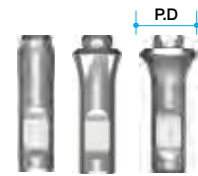

## Temporary Cylinder

- Cylinder screw(IRCS200) included

Type	Ref.C	Profile diameter
Octa	AANOTCO4010T	Ø4.0
Non-octa	AANOTCN4010T	
Octa	AANOTCO5010T	Ø5.0
Non-octa	AANOTCN5010T	
Octa	AANOTCO6010T	Ø6.0
Non-octa	AANOTCN6010T	

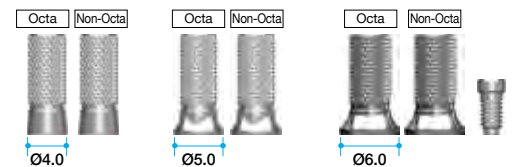

## EZ Post Cylinder

(Octa)

- Cylinder screw(IRCS200) included

Type	Ref.C	Profile Height(mm)	Post Height(mm)
Octa	AAOECO4005T	Ø4.0	5.5
	AAOECO4007T		7.0
Non-Octa	AAOECN4005T	Ø4.0	5.5
	AAOECN4007T		7.0
Octa	AAOECO5005T	Ø5.0	5.5
	AAOECO5007T		7.0
Non-Octa	AAOECN5005T	Ø5.0	5.5
	AAOECN5007T		7.0
Octa	AAOECO6005T	Ø6.0	5.5
	AAOECO6007T		7.0
Non-Octa	AAOECN6005T	Ø6.0	5.5
	AAOECN6007T		7.0

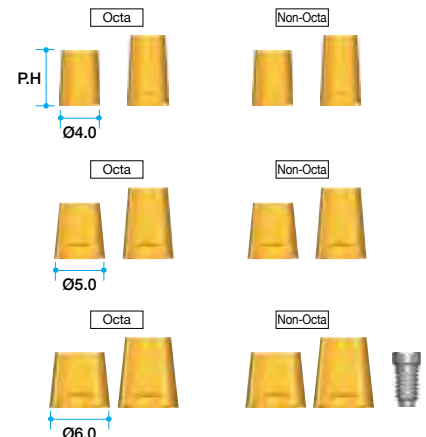



# ➔ Abutment Options

## Gold Cylinder

- Cylinder screw(IRCS200) included

Type	Ref.C	Profile diameter(mm)
Octa	AANGCO4000T	Ø4.0
Non-octa	AANGCN4000T	
Octa	IOGO100T	Ø5.0
Non-octa	IIGN100T	
Octa	AANGCO6000T	Ø6.0
Non-octa	AANGCN6000T	

- For customizing abutment for screw retained multi-unit restoration. - Available in both hex (red) and non-hex (white).
- Melting point of gold alloy : 1400~1450°C
- Threaded sleeves allow for better retention of resin or wax.
- Available in three diameters (4.0mm, 5.0mm & 6.0mm).
- Recommend torque : 30Ncm

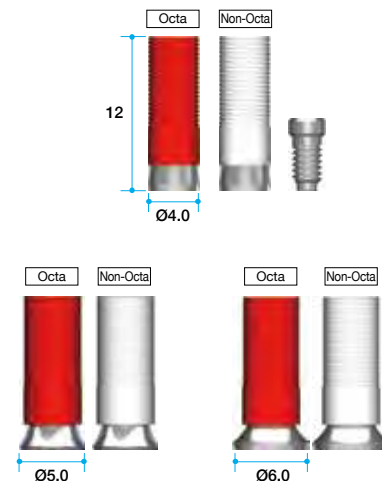

## CCM Cylinder

- Cylinder screw(IRCS200) included

Type	Ref.C	Profile diameter(mm)
Octa	AANCCO4000T	Ø4.0
Non-octa	AANCCN4000T	
Octa	AANCCO5000T	Ø5.0
Non-octa	AANCCN5000T	
Octa	AANCCO6000T	Ø6.0
Non-octa	AANCCN6000T	

- Threaded sleeves allow for better retention of resin or wax.- Available in both hex (purple) and non-hex (yellow) and three diameters (4.0mm, 5.0mm & 6.0mm).
- Recommend torque : 30Ncm
- Refer to p.23 for CCM instructions and characteristics.

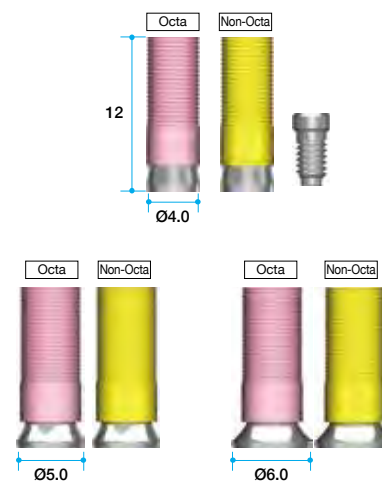

## Plastic Cylinder

- Cylinder screw(IRCS200) included

Type	Ref.C	Profile diameter(mm)
Octa	AAOTCO4010T	Ø4.0
Non-octa	AAOTCN4010T	
Octa	IOPH100T	Ø5.0
Non-octa	IOPN100T	
Octa	AAOTCO6010T	Ø6.0
Non-octa	AAOTCN6010T	

- Economical option.
- Used for customizing abutment for screw retained multi-unit restorations. - Available in both octa (red) and non-octa (white)
- Threaded sleeves allow for better retention of resin or wax.

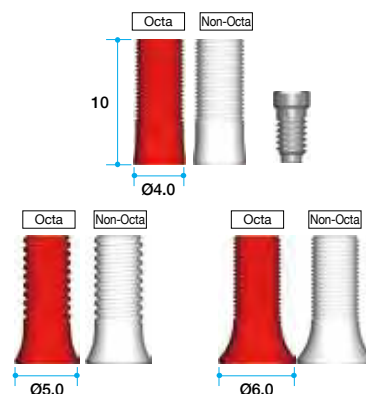

# ➔ Abutment Level / Multi-Unit Prosthesis

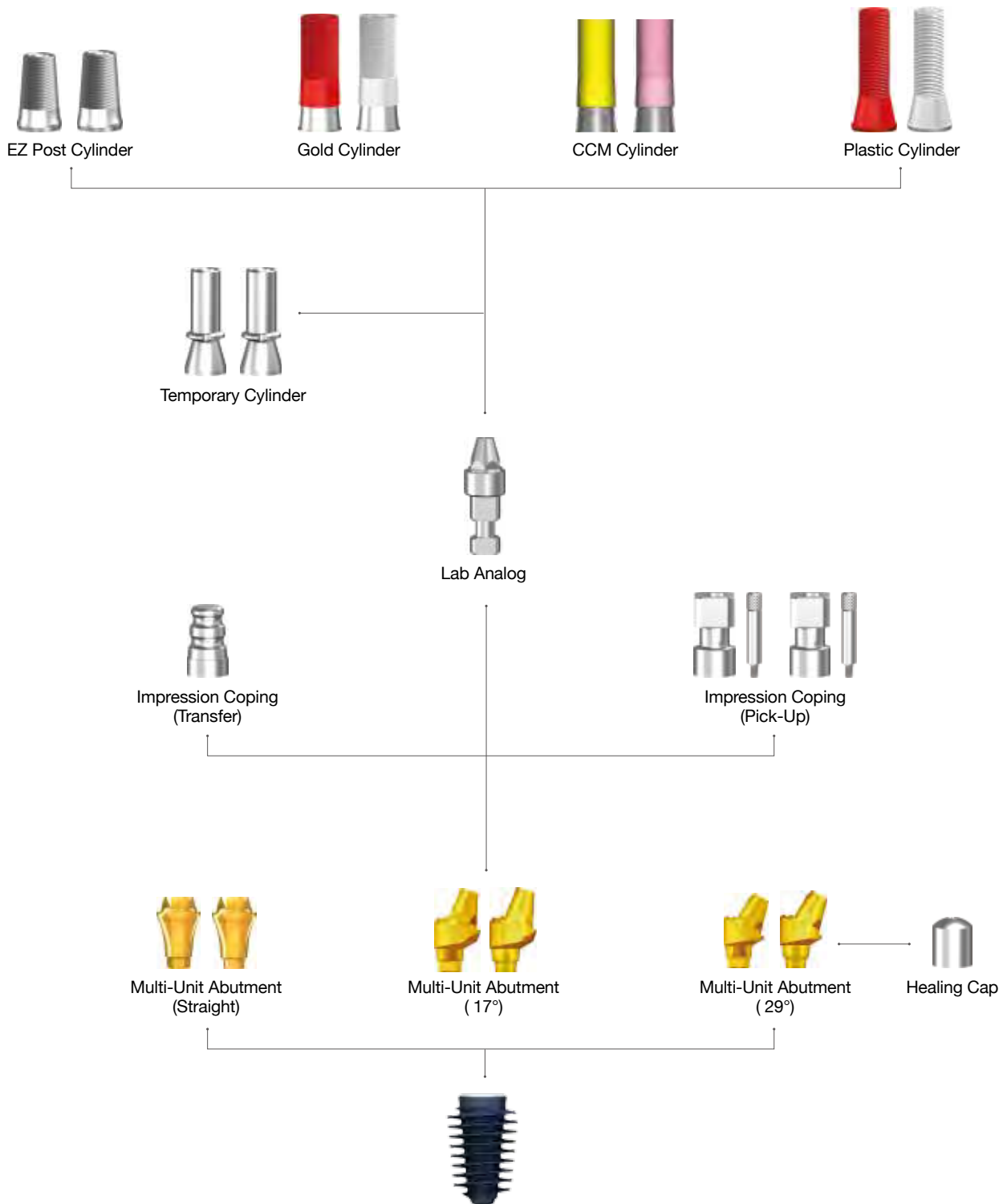

# ➔ Abutment Options

## Multi-Unit Abutment (17°)

- Multi Post Screw(AANMSF/AANMST) included

Ref.C	Cuff Height (mm)
AANMUH50317T	3.5
AANMUH50417T	4.5
AANMUH50517T	5.5
AANMUN50317T	3.5
AANMUN50417T	4.5
AANMUN50517T	5.5



## Multi-Unit Abutment (29°)

- Multi Post Screw(AANMSF/AANMST) included

Ref.C	Cuff Height (mm)
AANMUH50329T	3.5
AANMUH50429T	4.5
AANMUH50529T	5.5
AANMUH50629T	6.5
AANMUN50329T	3.5
AANMUN50429T	4.5
AANMUN50529T	5.5
AANMUN50629T	6.5

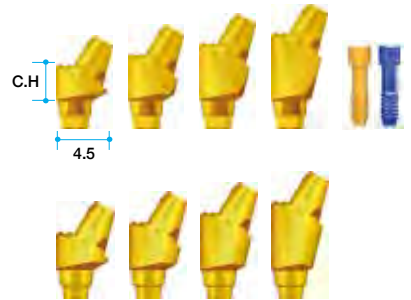

## Multi-Unit Abutment (Straight)

- Multi Unit Abutment Screw included

Ref.C	Cuff Height (mm)
AANMUH5020T	2.0
AANMUH5030T	3.0
AANMUH5040T	4.0
AANMUH5050T	5.0
AANMUN5020T	2.0
AANMUN5030T	3.0
AANMUN5040T	4.0
AANMUN5050T	5.0



# ➔ Abutment Options

## Healing Cap

Ref.C	Profile diameter(mm)
REC600	Ø5.0



## Impression Coping (Transfer)

Ref.C	Profile diameter(mm)
RITE480	Ø4.8



## Impression Coping (Pick-Up)

- Guide Pin (RICG150) included

Ref.C	Height(mm)
RIEH480T	9.4
RIEN480T	

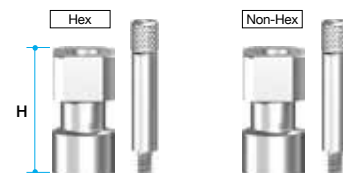

## Lab Analog

Ref.C	Profile diameter(mm)
RELA300	Ø4.8



## Temporary Cylinder

- Cylinder Screw (TASH140) included

Ref.C	Profile diameter(mm)
ETH100T	Ø4.8
ETN100T	

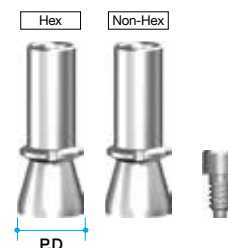

## EZ Post Cylinder

- Cylinder Screw (TASH140) included

Ref.C	Profile diameter(mm)
RCA900T	Ø5.0
RCA800T	



## Gold Cylinder

- Cylinder Screw (TASH140) included

Sleeve Color Vision	Ref.C	Profile diameter(mm)
Red	REGC200T	Ø5.0
White	REGC100T	



## CCM Cylinder

- Cylinder Screw (TASH140) included

Sleeve Color Vision	Ref.C	Profile diameter(mm)
Pink	RCA5013HT	Ø4.8
Yellow	RCA5013NT	

• Refer to p.23 for CCM instructions and characteristics.

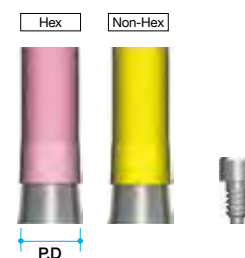

# ➔ Abutment Options

## Plastic Cylinder

- Cylinder Screw (TASH140) included

Sleeve Color Vision	Ref.C	Profile diameter(mm)
Pink	RPEH100T	Ø5.2
Yellow	RPEN100T	

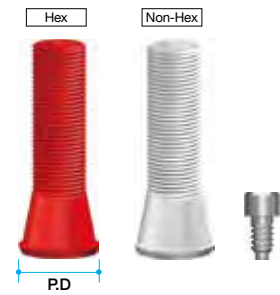

# ➔ Instrument

## Multi Unit Driver

(Straight)

(Hex 2.0)

Type	Ref.C	Length(mm)
Short	TCMMUDS20	10
Long	TCMMUDL20	15

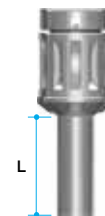

# ➔ Abutment Level / Flat Abutment Prosthesis

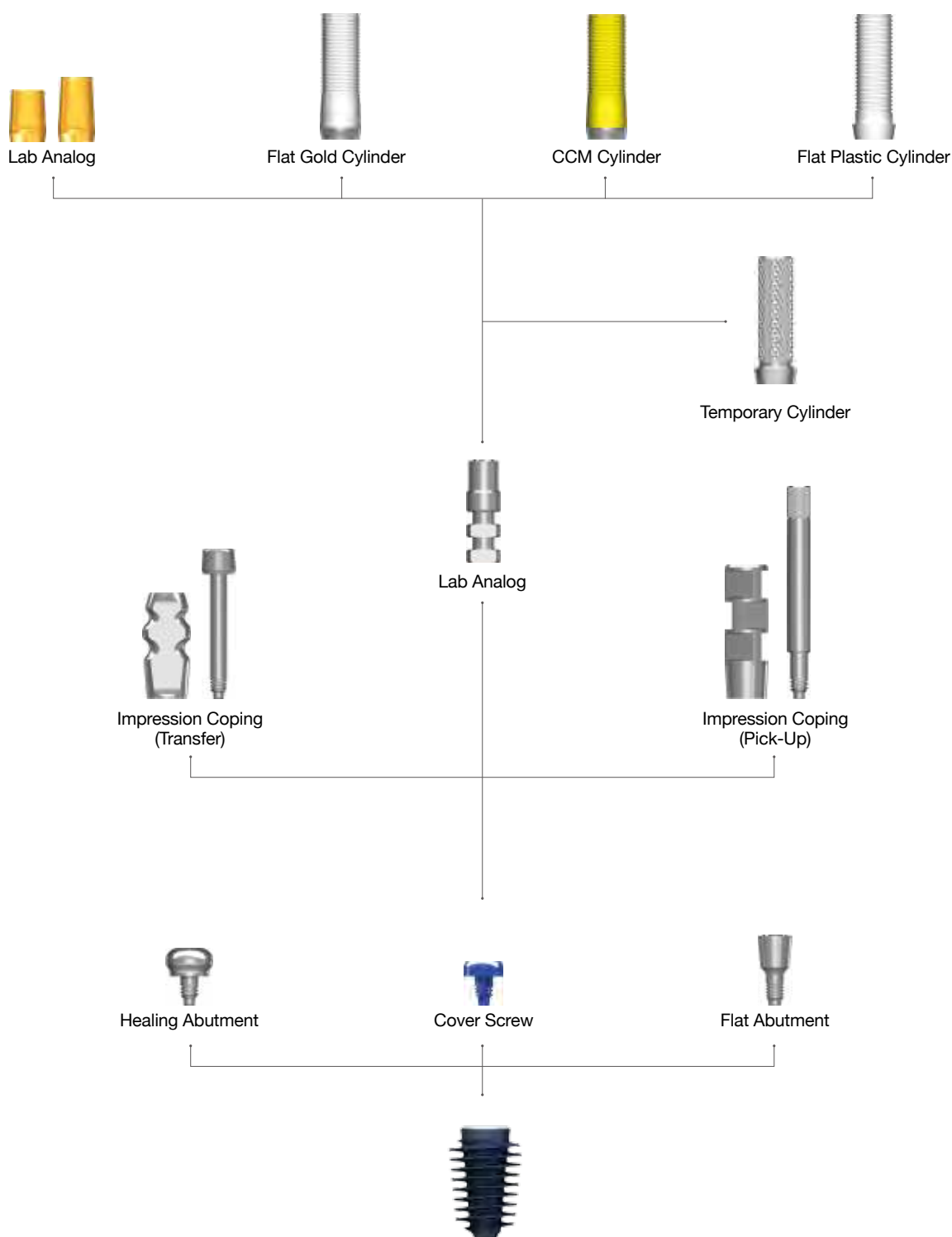

# ➔ Abutment Options

## Flat Abutment

Ref.C	Profile diameter (mm)	Cuff Height (mm)
AANFAL3510	Ø3.5	1
AANFAL3520		2
AANFAL3530		3
AANFAL3540		4
AANFAL3550		5



## Flat Cover Screw

Ref.C	Profile diameter (mm)
FCS3510	Ø3.5



## Healing Abutment

Ref.C	Height(mm)
FHA402	1
FHA403	2
FHA404	3



## Impression Coping (Transfer)

- Guide pin (FGPT) included

Ref.C	Profile diameter (mm)	Height (mm)
FIT4012T	Ø3.5	9.5

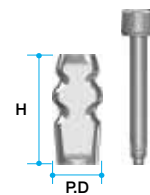

## Impression Coping (Pick-Up)

- Guide pin (FGPP15) included

Ref.C	Profile diameter (mm)	Height (mm)
FIP4012T	Ø3.5	12

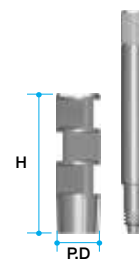

## Flat Lab Analog

Ref.C	Profile diameter (mm)	Height (mm)
FLA3512	Ø3.5	12

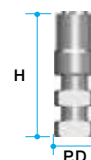



### Flat Temporary Cylinder

- Flat cylinder screw (FAS) included

Ref.C	Profile diameter (mm)
FTC4012T	Ø4.0



### Flat EZ Post Cylinder

- Flat cylinder screw (FAS) included

Ref.C	Height (mm)
FEC4005T	5.5
FEC4007T	7.0



### Flat Gold Cylinder

- Flat cylinder screw (FAS) included

Ref.C	Profile diameter (mm)
FGC4012T	Ø3.8

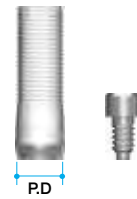

### Flat CCM Cylinder

- Flat cylinder screw (FAS) included

Ref.C	Profile diameter (mm)
FCC4012T	Ø3.8

• Refer to p.23 for CCM instructions and characteristics.

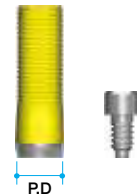

### Flat Plastic Cylinder

- Flat cylinder screw (FAS) included

Ref.C	Profile diameter (mm)
FPC4012T	Ø4.0



## ➔ Instrument

### Hand Driver (Hex 1.6)

Type	Ref.C	Length (mm)
Short	TCMHDS1600	10
Long	TCMHDL1600	15



# ➔ Overdenture Prosthesis



Retentive cap set



Lab analog



Impression coping



Meg-Rhein



# ➔ Meg-Rhein

## Meg-Rhein

Ref.C	Cuff Height (mm)
ADR00	0
ADR01	1.0
ADR02	2.0
ADR03	3.0
ADR04	4.0
ADR05	5.0
ADR06	6.0

- Perfect compatibility with the Rhein83 from Italy.
- Recommend torque ; 35Ncm.



# ➔ Meg-Rhein Option

## 4 Retentive Caps (Violet)

Ref.C
140CEV

- Violet cap(2.7kg) - For refill (4ea/pack)



## 4 Retentive Caps (White)

Ref.C
140CET

- White cap(1.8kg) - For refill (4ea/pack)



## 2 Stainless Steel Housing

Ref.C
141CAE

- 2ea/pack



# ➔ Meg-Rhein Option

## Insertion Tool

Ref.C  
085IAC

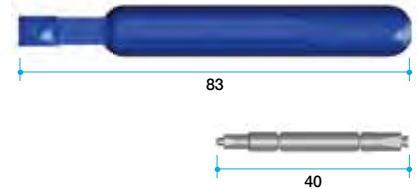

## Removal Tool

Ref.C  
091EC

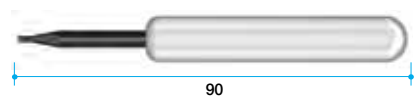

## Stainless Impression Coping (pick up)

Ref.C  
044CAIN

- 2ea/pack
- Italy - Rhein83 products.
- For accurate (pick-up type) impression.
- Metal with groove design to prevent from swaying.



## Lab Analog

Ref.C  
PLA

- To make denture model.



# How to seal a screw hole? Try Easy Seal!

Foul odor? Bacterial colony? Metal hue?  
Hard to remove? Inconvenient process?



## Easy to fill & Remove

- ✓ Convenient size  
: Diameter (Ø2.1, Ø2.2, Ø2.4, Ø3.1)  
Length (1, 2, 3, 4, 5mm and free)
- ✓ Convenient tools  
: EZ carrier
- ✓ Retrievable material (Silicon)

### TIP! EZ Seal Choice

Choose EZ Seal length which is  
Depth- 3mm (resin)!

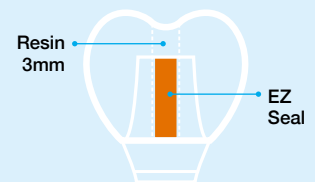

Implant completed in  
a simple and convenient way!

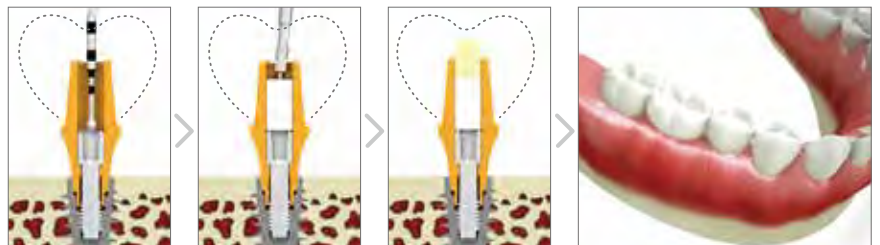

1. Measure depth

2. Fill the EZ Seal

3. Fill the resin

4. Perfect final prosthetic

Choose appropriately  
for your system!

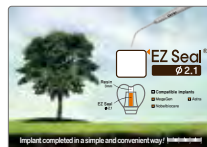

Ref. C : EZSP21K  
System : AnyRidge



Ref. C : EZSP22K  
System : AnyOne



Ref. C : EZSP24K  
System : EZ Plus, MegaFix



Ref. C : EZSP31K  
System : Rescue

# ➔ Surgical Kit / Standard (KARIN3003)

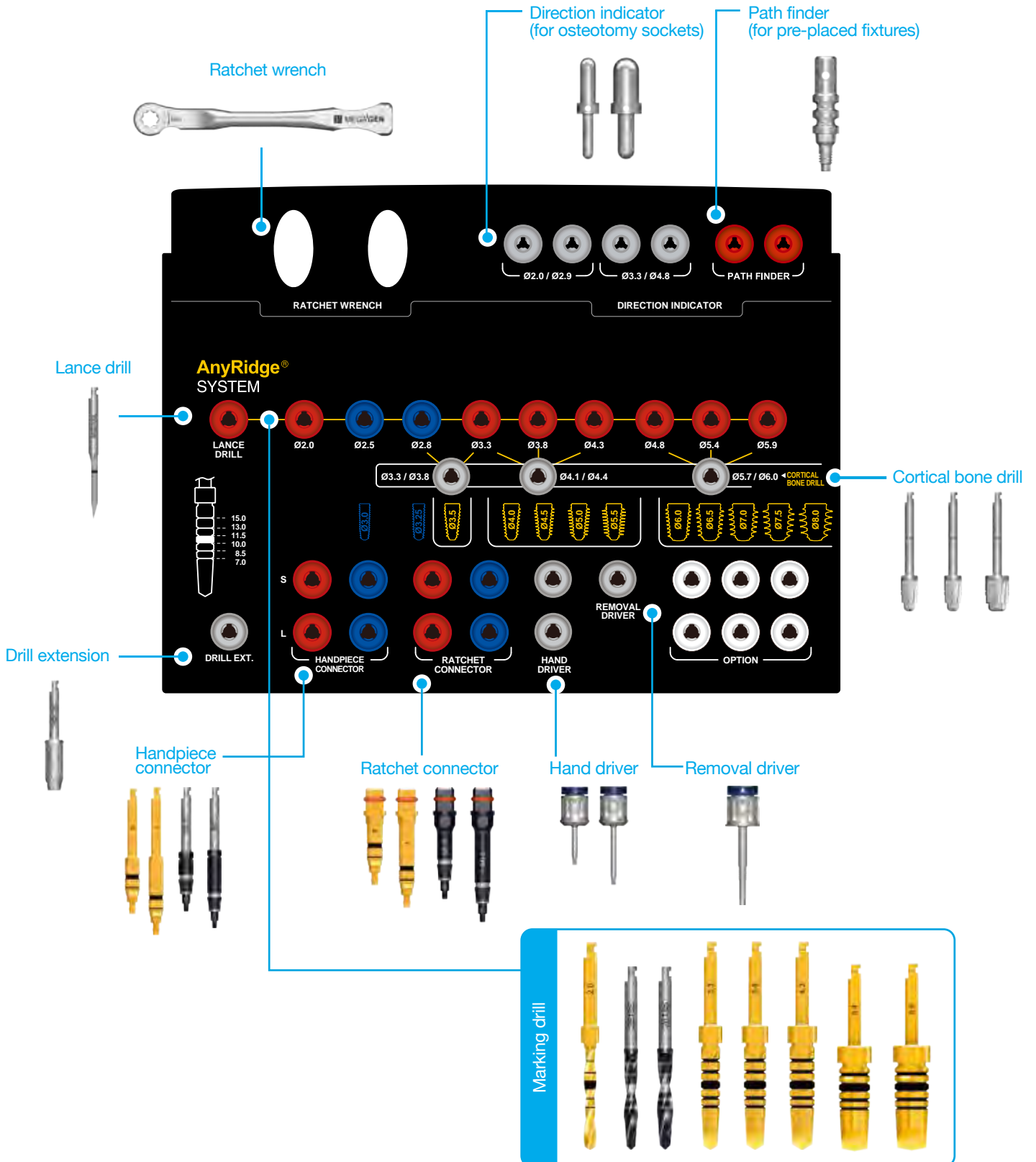

# ➔ Surgical Kit / Full (KARIN3001)

**Ratchet wrench**

**Direction indicator (for osteotomy sockets)**

**Path finder (for pre-placed fixtures)**

**Lance drill**

**Cortical bone drill**

**Handpiece connector**

**Ratchet connector**

**Hand driver**

**Drill extension**

**Point Trephine Bur**

**Trephine Bur**

**Removal driver**

**AnyRidge® SYSTEM**

**STOPPER DRILL**

**MARKING DRILL**

**DRILL EXT.**

**POINT TRE.**

**2 STEP DRILL → TREPHINE BUR**

**REMOVAL DRIVER**

**OPTION**

**STOPPER DRILL**

**MARKING DRILL**

Ø3.3 / Ø3.8    Ø4.1 / Ø4.4    Ø5.7 / Ø6.0

Ø2.0 / Ø2.9    Ø3.3 / Ø4.8    PATH FINDER

Ø2.0    Ø2.5    Ø2.8    Ø3.3    Ø3.8    Ø4.3    Ø4.8    Ø5.4    Ø5.9

11.5mm    10.0mm    8.5mm    7.0mm

15    13    11.5    10    8.5    7

Ø2.5 / Ø3.5    Ø4.0 / Ø5.0

S    L    S    L    S    L

S    L    S    L

# ➔ Surgical Components

## Lance Drill

Type	Ref.C	Diameter
Long	MGD100L	Ø2.0

- Useful to make an indentation on cortical bone to confirm the exact drilling location.
- Advisable to go into the bone to the full length of a fixture.

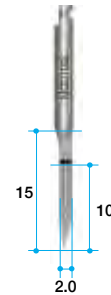

## Drill Extension

Ref.C
MDE150

- Extends drills & other handpiece tools.
- No more than 35Ncm torque : Can be distorted when too much force is applied.



## Marking Drill

Ref.C	Length (mm)	Diameter
TANTDF2018	18	Ø2.0
SD2518S		Ø2.5
SD2818S		Ø2.8
TANSDF3318		Ø3.3
TANSDF3818		Ø3.8
TANSDF4318	15	Ø4.3
TANSDF4815		Ø4.8
TANSDF5415		Ø5.4
TANSDF5915		Ø5.9

- Each drill has calibrations from 7.0 to 18.0mm. (4.8, 5.4 and 5.9 drills have calibrations up to 15.0mm)
- Easy to recognize by dual marking systems. (Groove and laser marking)



## Cortical Drill

Ref.C	D1	D2
TANCDL3500	Ø3.3	Ø3.8
TANCDL4055	Ø4.1	Ø4.4
TANCDL6080	Ø5.7	Ø6.0

- Removes cortical bone and enlarges socket, especially in hard bone.
- Similar function with counter-sink drill of other systems.
- Each drill has two steps of diameter for convenience.

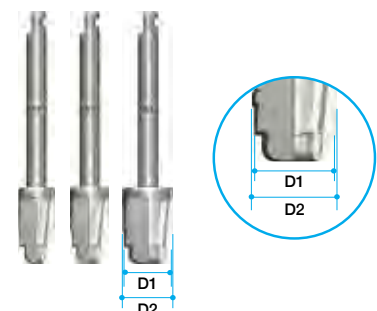



## Path Finder

Ref.C	Length (mm)
TANPFF3580	10

- After placing a fixture, a path finder can be connected to check pre-placed fixture is parallel.
- Gingival depth can be measured with the grooves, especially in flapless surgeries.

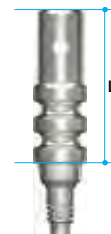

## Handpiece Connector

Type	Ref.C	Length (mm)
AnyRidge	TANHCU	5
	TANHCS	10
	TANHCL	15
MiNi	HCS17	10
	HCL17	15

- Delivers torque for the placement of a fixture with a handpiece.
- Easy and secure pick-up and delivery.
- Ultrashort is not included in the kit.
- Used to place implant without mount.
- Marks on the shaft can indicate the position of fixture platform, especially in flapless surgery.

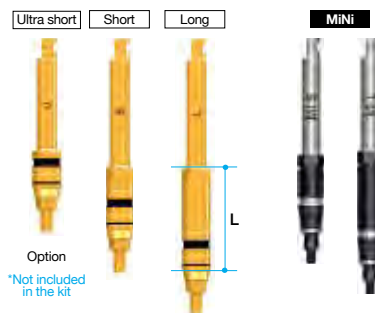

## Ratchet Connector

Type	Ref.C	Length (mm)
AnyRidge	TANREU	6
	TANRES	10
	TANREL	15
MiNi	RCS17	15
	RCL17	20

- Delivers torque for the placement or removal of a fixture with a ratchet wrench.
- Secure a ratchet extension to a fixture before exerting force.
- Too much torque force can result in damage to hex of a fixture.
- Marks on the shaft can indicate the position of fixture platform, especially in flapless surgery.
- Ultra short is not included in the kit.

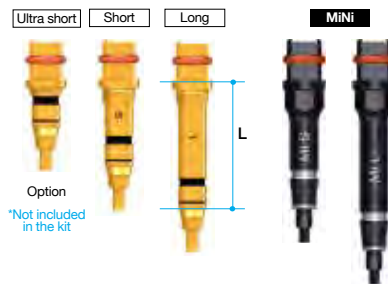

## Direction Indicator

Ref.C	Length (mm)
MDI2029	Ø1.9 / Ø2.8
MDI3348	Ø3.2 / Ø4.7

- Confirms drilling direction and location during drilling.
- To check drilling depth and position.

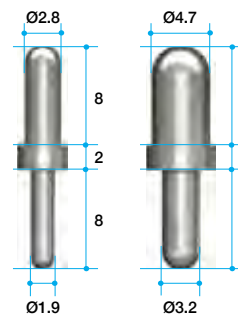

# ➔ Surgical components

## Hand Driver (1.2Hex)

Ref.C	Length (mm)
TCMHDS1200	Ø1.9 / Ø2.8
TCMHDL1200	Ø3.2 / Ø4.7

- Small but well functioning non-slip head.
- Slender shaft allows easy access to screw.
- Torque wrench can be connected directly to the hand driver without adaptor.
- Hex tip is strong enough to exert 35~40Ncm torque force.

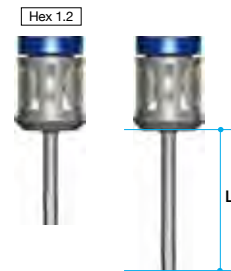

## Abutment Removal Driver

Ref.C	Length (mm)
TANMRD18	17.5
TANMRD25	25.0

- Used to remove final abutment ; use after removing abutment screw.
- Insert straight into the abutment and rotate clockwise.
- Long abutment removal driver is to disconnect an abutment with a cemented crown.

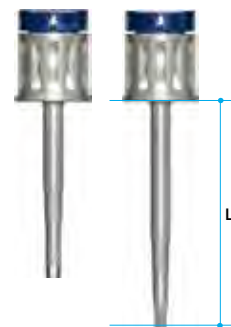

## Ratchet Wrench

Ref.C
MRW040S

- Used to exert more force than handpiece.
- No bearing system : No breakage and corrosion problems
- Attaches to Ratchet extension.
- Arrow laser marking indicates direction of force.



## Trephine Bur

Ref.C	Diameter
TANTBL2535	Ø3.5 (In.Ø2.5)
TANTBL4050	Ø5.0 (In.Ø4.0)

- Useful to make an osteotomy socket for wider diameter.
- Helpful to collect autogenous bone.
- Useful to remove failed and fractured fixtures.
- Marked depths 7, 8.5, 10, 11.5, 13mm, same depths as fixtures.

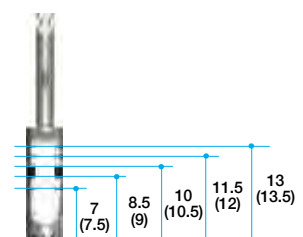

### Point Trephine Bur

Ref.C	Diameter
SPTB4050	Ø5.0 (In.Ø4.0)



### Stopper Drill

Ref.C	Length (mm)	Diameter
TANTDF2007	7	Ø2.0
TANTDF2008	8.5	
TANTDF2010	10	
TANTDF2011	11.5	
SD2807M	7	Ø2.8
SD2808M	8.5	
SD2810M	10	
SD2811M	11.5	
TANSDF3307	7	Ø3.3
TANSDF3308	8.5	
TANSDF3310	10	
TANSDF3311	11.5	
TANSDF4807	7	Ø4.8
TANSDF4808	8.5	
TANSDF4810	10	
TANSDF4811	11.5	



### Ball Driver

Type	Ref.c
Handpiece connector(Short)	TBH250S
Handpiece connector(Long)	TBH250L
Ratchet Extension(Short)	TBR250S
Ratchet Extension(Long)	TBR250L
Toque Driver(Short)	TBT250S
Toque Driver(Long)	TBT250L



- For seating the Ball Abutment onto the fixture, can also be connected to Torque Wrench.
- Can connect to a Handpiece, Ratchet or Torque Wrench. available in long or short.

# ➔ Bone Profiler Kit (KARBP3000)

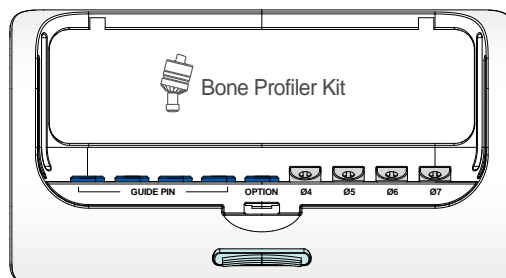

## Bone Profiler & Guide pin

Ref.C	Profile diameter	Length (mm)
TANBPL40G	Ø4	13
TANBPL50G	Ø5	
TANBPS60G	Ø6	8
TANBPS70G	Ø7	

- Removes bone around the fixture to allow adequate size of healing abutment.
- Place a guide pin into a fixture and choose a bone profiler to fit the situation.
- Each package includes a Bone profiler, a guide pin and a guide pin holder.

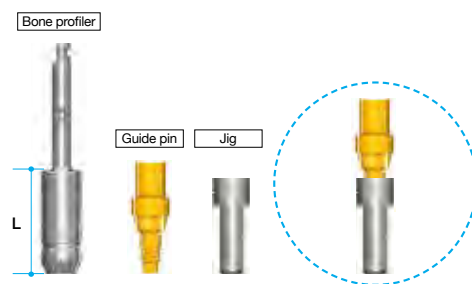

# ➔ Optional surgical components

: not included in a surgical kit

: may be purchased separately and placed in the spaces provided in the surgical kit

## Trephine Bur Stopper & Jig

Ref.C	Length (mm)
TANTSF2307	7.0
TANTSF2308	8.5
TANTSF2310	10.0
TANTSF2311	11.5
MRTBJ	-

- Controls the depth of trephination with a stopper placed into the trephine.
- Especially useful in cases with limited height bone.



## Hand Fixture Inserter

Ref.C
TANMI

- Specially designed for manual placement of AnyRidge fixture.
- Especially useful at immediate implant placement on maxilla anterior.



# ➔ Prosthesis Kit (KANPK3000)

## Torque Wrench & Adapter

Type	Ref.c
Torque Wrench	MTW300A
Torque Wrench Adapter(Ratchet)	TTAR100

- Torque Wrench has torque options from 15Ncm to 45Ncm and is used for final tightening of the abutment screw into the fixture
- Torque wrench provides torque to screw when connecting prosthetics to implant.

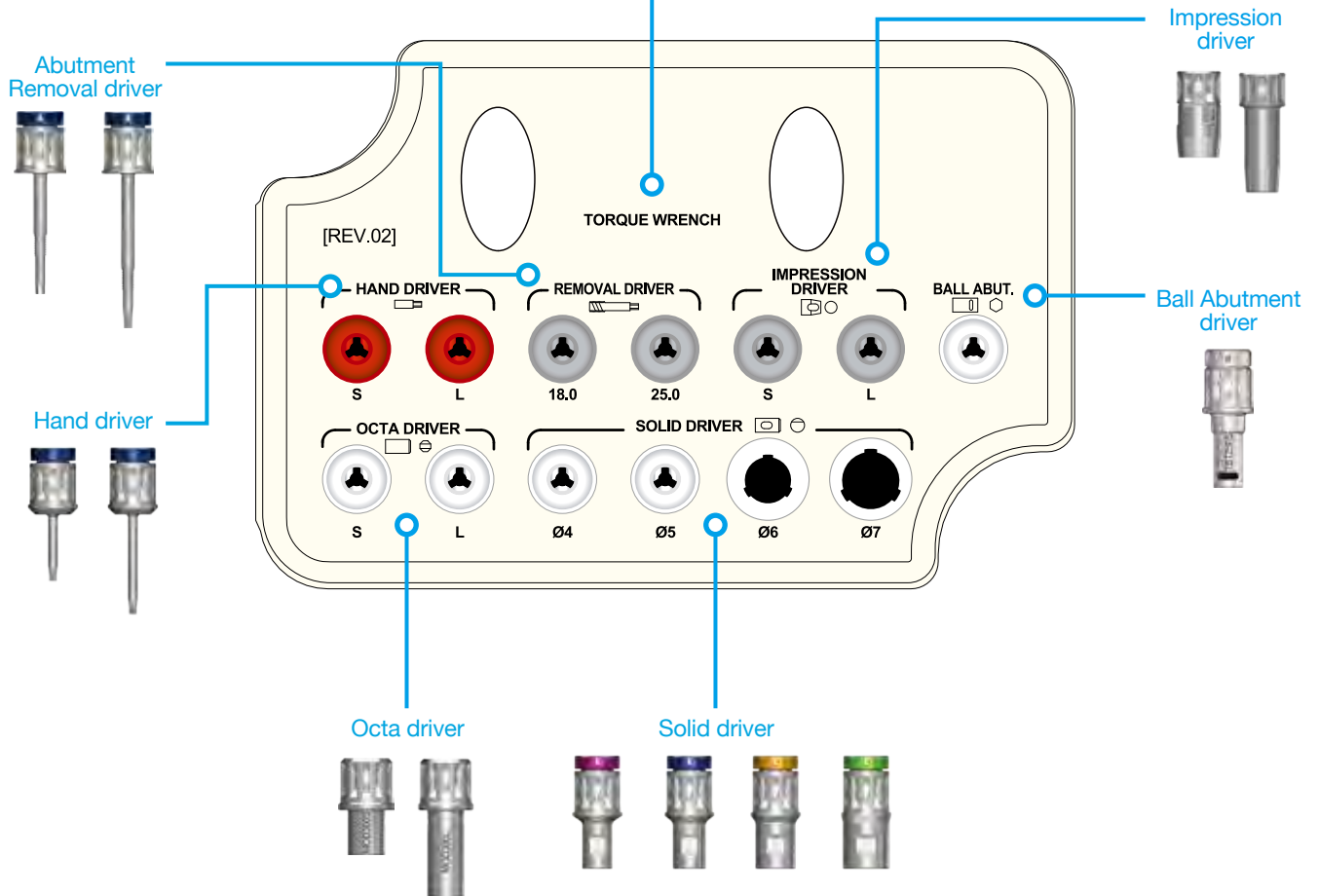

# ➔ Abutment selection guide kit (KANASG3000)

- Colors indicate different cuff heights (Yellow : 2mm, White : 3mm, Pink : 4mm, Red : 5mm)
- Store 2pieces in each container
- Use autoclave to sterilize

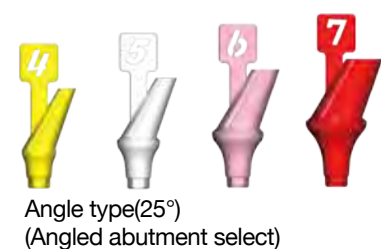
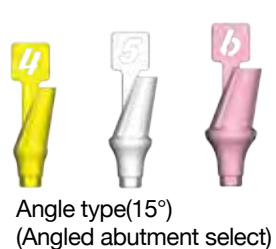
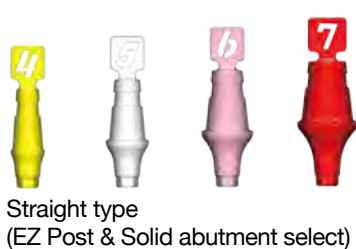

# → BonEx (KBECS3000)

## Chisel & Expander

Ref.C	Diameter	Length (mm)	Marking line (mm)
TCMBE2413	Ø2.4	13	7 / 8.5 / 10 / 11.5
TCMBE2813	Ø2.8		
TCMBE3313	Ø3.3		
TCMBE3813	Ø3.8		
TCMBE4313	Ø4.3		
TCMBE4813	Ø4.8		

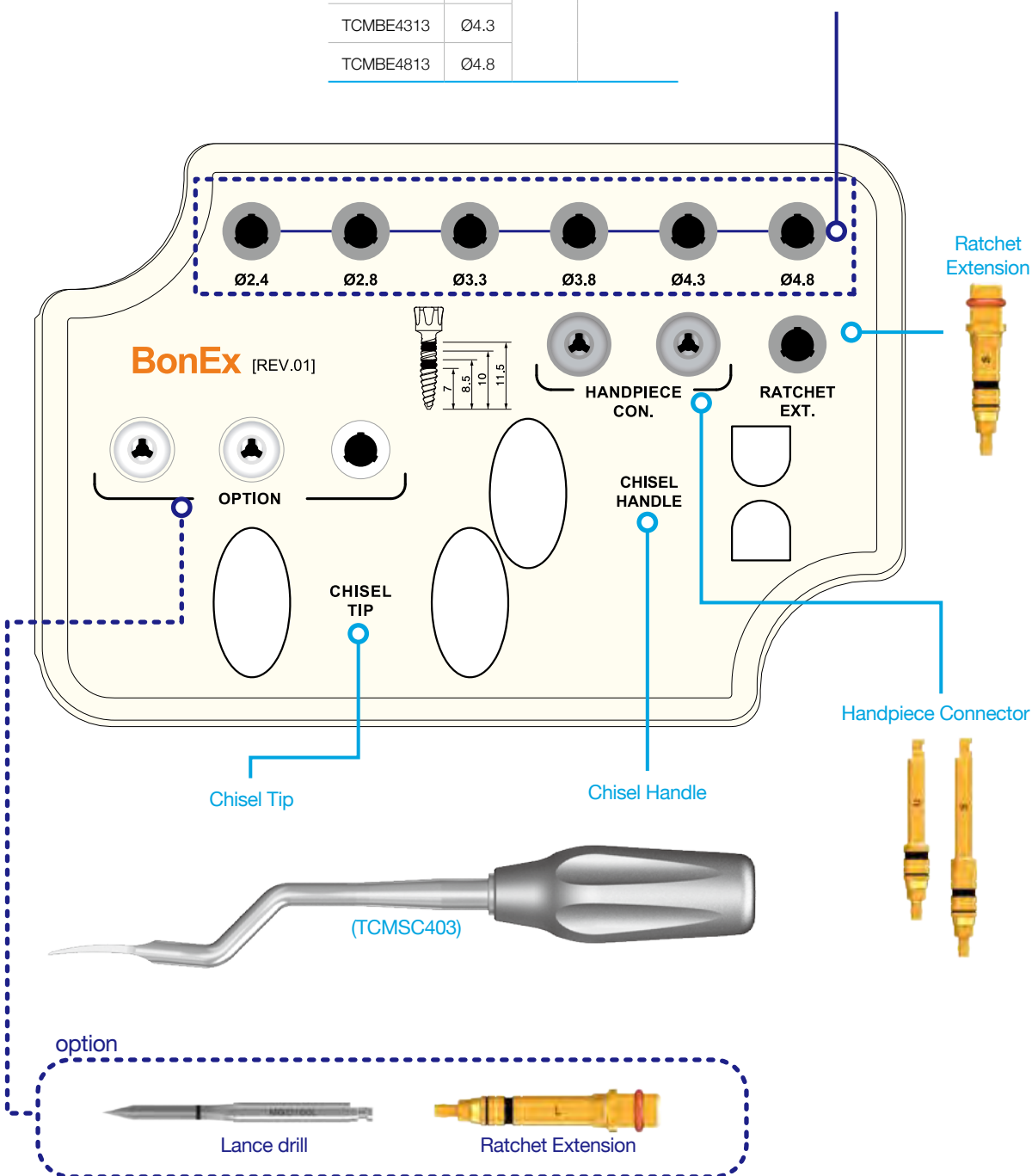

# AnyRidge®



**Gangnam Office** 5F MegaGen Tower, 607 Seolleung-ro, Gangnam-gu, Seoul, Korea  
**Head Office & Factory** 472 Hanjangu-ro, Jain-myun, Gyeongsan, Gyeongbuk, Korea  
[www.imegagen.com](http://www.imegagen.com)

T. +82-1566-2338  
T. +82-1544-2285